

Instructions and Maintenance User Manual

KD5815



Content

Packing, Storage, Stacking, Opening and Warning.....	3
Packing.....	3
Storage.....	3
Stacking.....	3
Opening.....	3
Warning.....	3
Conserving the manual.....	3
1. Abstract.....	4
2. Usages.....	4
2.1 Important Technical Reference.....	4
2.2 Working conditions:.....	4
2.3 Basic Structure of the Product.....	5
3. Installation of the Safety Features.....	5
4. Installation and Adjustment of the Equipment.....	5
5. Safety Instruction.....	6
5.1 Safety Rules.....	6
5.2 Warning Logo.....	7
6. Use and Operation.....	8
6.1 Preparation.....	8
6.2 Raising.....	8
6.3 Stopping.....	8
6.4 Locking.....	8
6.5 Lowering.....	8
6.6 Lowering from limited height to the lowest:.....	8
6.7 Control panel for reference.....	8
7. Maintenance and Care.....	9
7.1 Maintaining Cleanliness.....	9
7.2 Regular Check-ups.....	9
7.3 Maintenance of the Hydraulic System.....	9
8. Common Problems and Solution Methods.....	10
9. Important Information for the User.....	10
9.1 Important Information Regarding Purchase of the Machine.....	10
9.2 Quality Assurance after Opening the Product.....	10
9.3 Foundation.....	10
9.4 Important Items.....	10
10. Components Chart.....	11
10.1 Explosion list for reference.....	11
10.2 Layout diagram.....	13
10.3 Circuit diagram.....	14
10.4 Hydraulic system.....	16
10.5 Hose Connection.....	16
10.6 Cable System.....	17
10.7 Safety Lock System.....	18
10.8 Foundation.....	19

Packing, Storage, Stacking, Opening and Warning

All packing, lifting, handling, transport and unpacking operations are to be performed exclusively by expert personnel with knowledge of the vehicle lift and the contents of this manual.

Packing

There are two means to pack the two post lift:

1. Complete command post, complete with carriage, hydraulic cylinder, longer arm, shorter arm, lower cover board, and so on by only one packing.
2. One packing for Electrical control box and power station and all the left parts by a separate packing.

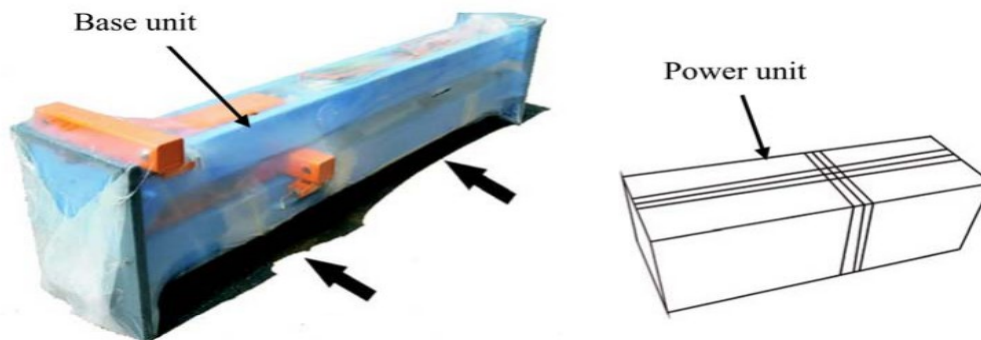

Lift Net weight is 680kg. Lift gross weight is 710kg.

Storage

Pack boxes always be kept in a covered, protected place, at a temperature between -10 degree and +40 degree And must not be exposed to direct sunlight and must not be caught in the rain.

Stacking

The type of packing allows the possibility of stacking up to 3 crates.

Up to 3 crates may be stacked one upon the other on Lorries or in containers if property positioned and provided they are restrained to prevent falling.

Opening

When the crates arrive, check that the machine has not been damaged during transport and that all parts listed are present. The crates must be opened using all possible precautionary measure to avoid damaging the machine or its parts. Make sure that parts do not fall from the crate during opening.

Warning

This manual has been prepared for workshop personnel expert in the use of the lift (operator) and technicians responsible for routine maintenance (maintenance fitter): read the manual before carrying out any operation with the lift and /or the packing. This manual contains important information regarding:

THE PERSONAL SAFETY OF operators and maintenance workers

THE SAFETY OF LIFTED VEHICLES

Conserving the manual

The manual is an integral part of the lift, which it should always accompany even if the unit is sold .The manual, must be kept in the vicinity of the lift in an easily accessible place so that the operator and maintenance staff must be able to locate and consult the manual quickly at any time. Lift rack has been designed and built in compliance with the following.

1. Abstract

The 2 post lifts are products of our research and development division: a two-cylinder steel-balanced hydraulic lift. Its special features include a lifting capacity of 4000kg.; a hydraulic pulling system with a hydraulic control activator providing power; power supplied by oil cylinders installed in its columns; a chain system connected through the columns on a slide unit allowing free action of the slide unit and giving the lift the capacity to reach relatively high; synchronized steel cable pulling action and slide unit movement; an electric safety locking system that backs off the lift when activated; one-way and two 2-passage exchange valves in the hydraulic system; and a hydraulic cylinder that freely positions and locks itself. The entire machine features great width capacity with a space between columns of 2820mm. The tray goes as low as 110mm for convenience in the lift and repair of luxury vehicles.

The type with clear floor design, we install beam with a bar of height limit on the top of lift. This height limit controlling device is achieved by electric control. The type of lift can be used for lifting and maintenance of high vehicles.

2. Usages

This kind of product is used to lift all types of small vehicles, and to aid in the maintenance and repair of these vehicles. The maximum lifting capacity of 2 Post lift with base plate is 4000kgs.

The lift is only used for lifting cars, other usages are prohibited.

2.1 Important Technical Reference

Model type	KD814
Type	Floor Plate
Capacity	4200Kg
Lifting time	< 55s; adjustable
Descent time	> 30s; adjustable
Max. lifting height	1900mm
Min. lifting height	110mm
Overall width	3470mm
Overall height	2826mm
Power supply	230V/50HZ/1PH
Power	2.2 KW
Noise	≤70dB
Safety catch type	Magnetic Solenoid

2.2 Working conditions:

The machine should be used in below condition.

- a. Temperature limit of air should be between 0°C—40°C.
- b. Air humidity: ≤80% at 30°C
- c. Transportation and storage temperature: -25°C ~ +55°C

4200kg

Express the rated load is 4000kg , don't allow the lift load weigh excess 4000kg.



This symbol express attention should be taken for electrical hazards



This symbol expresses the earth connecting point.

2.3 Basic Structure of the Product

Three parts of the product:

- The machine is comprised of: main columns, supporting columns, cradle, lubricant stand, safety system and fixed skeleton, bottom plate or top beam etc.
- The electric control system is comprised of various electrical components that control the various movements of the lift.
- The hydraulic control system is comprised of a hydraulic pump activator, hydraulic cylinder, pipes and other various components to aid in the various functions of the lift.

3. Installation of the Safety Features

3.1 Safety Stop Mechanism

Inside each of the main and support columns is an electric safety stop feature. It is comprised of electro-magnetized steel, locking plate, lubricated lift collar safety plate, and support blocks on each column.

3.2 Safety Stop Movement Fundamentals

The locking plate relies on the weight and angle of each of the end faces, the entire top face adhering to mounting plate. When the collar rises, the angled mounting plate pushes open the locking plate to ascertain a certain height. When the collar becomes stuck in operation, or when the speed of descent produces unsafe circumstances, the locking plate block fits inside the aperture in the mounting plate, stopping the lift from further descent and activating the safety mechanism.

3.3 Adjustment of the Safety Mechanism

3.3.1 Adjustment of the magnetized axle core screw cap moves the locking plate from its natural state to insert into the groove of the mounting plate (with an empty load, ensure that the block can insert into the base of the groove of the mounting plate). When the lubricated stand is rising, you will be able to clearly hear a clacking inside the two columns.

3.3.2 When the magnetized steel is being drawn, check the two mounting plates are completely separated. Ensure that the main and supporting columns are separating at the same time, otherwise this could prove very unsafe.

4. Installation and Adjustment of the Equipment

4.1 Installation should be carried out by trained employees of the manufacturing company.

4.2 The installation site should have 230v, 1Ph or 400V, 3Ph power supply and reliable ground wires.

4.3 The incoming line should have 20A safety installation and a power supply switch. The minimum wire section area is 2.5 square millimeters.

4.4 The lift's foundation has the following requirements: the concrete should not be lower than 250 grades; the area of the foundation should be 3700mm long × 800mm wide × >250mm thick.

4.5 Installation Steps

4.5.1 When the concrete has solidified at the proper thickness, install the two columns into the floor of the installation site. Check and measure the dimensions and move into the proper place as needed by the user. After ensuring that the columns and floor are perpendicular, use steel plates and concrete to fill in any gaps between the base plate and floor. Use M18*160 anchor bolts to secure the base plate.

4.5.2 Lift and lock the two slide units into the first locking position. Connect the two synchronized steel cables according to needs. Adjust nuts (tighten the cable in position so the last thread screws against the nut, save the longer screws), and adjust the tension in the cables so that they are in the best position.

4.5.3 Connect the hydraulic system pipeline.

4.5.4 Add the oil: 10 Liters of Hydraulic Oil #46 in summer, # 32 in winter.

4.5.5 Affix the flat-ranged chain in the most logical position. Bring the slide blocks as low as they can go giving the cradle room to sway unobstructed but not sliding across the ground. When the product comes out of the factory, this first step should have already been set.

4.5.6 Lubricate the sliding blocks and grooves. (Use Formula 2 Grease)

4.6 Test for problems.

4.6.1 Preparing the vehicle.

Before trying a vehicle on the lift, give the equipment a thorough check. Check that all connections are tight and reliable. Make sure the levers operate smoothly and that the ends of the hydraulic pipes are fastened securely. Check that the power source is adequate, and that the ground wire is reliable. The generator should turn in a direction consistent with that of the gear pump. When the 'lock' button is pressed on the operating lever, the two magnets in the columns should be moving together.

4.6.2 Operation with an Empty Load

Check that the two sliding blocks are moving together and meet requirements. Regulate the tension in the steel cables so they meet requirements. The core axle line in the hydraulic cylinders should be equal to the core axle line in the columns (if not, adjust). The movement of the sliding blocks should be normal. The hydraulic pipeline should be free of leakage. The locking installation should be normally regulated, without any obstructions. Raise and lower two times.

4.6.3 Loading operation:

If all is working order with an empty load, move a car onto the lift. Repeatedly raise and lift the vehicle, first bringing it to about 1000mm, checking each working part of the lift and adjusting as needed. If everything is up to standard, raise the lift to a fixed height and lower, and then repeat.

NOTE: After the lift has been installed a debugged, it can be used for normal operation.

5. Safety Instruction

5.1 Safety Rules

Do not attempt to operate until you have read thoroughly and understand completely all instructions, rules, etc. contained in this manual. Failure to comply can result in accidents involving fire, electric shock, or serious personal injury. Keep owners manual and review frequently for continuous safe operation.

1. Know your machine.

For your own safety, read the owner's manual carefully. Learn its application and limitations as well as Specific potential hazards pertinent to this machine.

2. Keep work area clean.

Disorder area and working table will cause accident.

3. Do not use in dangerous environments.

Do not use power tools in damp or wet locations, or expose them to rain. Keeps work area well illuminated.

4. Keep non-professional people away.

All visitors should be kept at a safe distance from work area.

5. Wear proper apparel.

Avoid loose clothing, gloves, neckties, rings, bracelets, or jewelry, which could be caught in moving parts.

Non-slip footwear is recommended. Wear protective hair covering to contain long hair.

7. Don't maintenance the machine in running states.

The machine should be maintained such as lubrication, proper adjustment.

8. Before maintenance, accessory changing or assembling and reassemble motor, be sure to cut off the power form the power resource.

9. Never leave machine running unattached.

5.2 Warning Logo

 Zagrożenie		
 <p>Nie wchodzić pod pojazd podczas pracy podnośnika. Może to spowodować obrażenia lub śmierć.</p>	 <p>Ewakuwać się natychmiast, gdy pojazd zacznie się zsuwać z podnośnika. Może to spowodować obrażenia lub śmierć.</p>	
 Ostrzeżenie		
 <p>Podnośnik może być obsługiwany tylko przez osoby przeszkolone.</p>	 <p>Przed zniżaniem sprawdzić czy pod pojazdem lub ramionami podnośnika nie znajdują się żadne przeszkody.</p>	 <p>Unikać kołysania pojazdem. Mody jest podniesiony.</p>
 <p>Nie podnosić przy użyciu tylko jednej pary ramion.</p>	 <p>Nie podważać pojazdu po podniesieniu. Nie używać myki wystrząsaniowej do mycia podwozia.</p>	 <p>Trzymać stopy z dala od ramion i wózków podnośnika.</p>
 <p>Obługa obsługiwana jedynie przez osoby przeszkolone.</p>	 <p>Przed wejściem pod podnośnik upewnić się, że niekłada pod kołymi.</p>	 <p>Zakaz przebywania osób nieupoważnionych w obszarze roboczym.</p>
 <p>Ustawić pojazd za pomocą urządzeń w pobliżu odległości między ramionami.</p>	 <p>Nie wprowadzać żadnych zmian w konstrukcji podnośnika.</p>	 <p>Odczytać podnośnik od źródła zasilania przed otwarciem skrzynki sterującej.</p>
 Uwaga		
 <p>Przed korzystaniem z podnośnika przeczytać ze zrozumieniem instrukcję obsługi.</p>	 <p>Nie używać podnośnika w przypadku wystąpienia awarii.</p>	 <p>Ustawić pojazd proporcjonalnie z uwzględnieniem środka ciężkości.</p>

You must support the car on its skirt or bridge by positioning the center of the rubber chassis, so that the support area is perfectly centered. When the vehicle leaves the ground (100-150mm), rock the car a bit checking that lift is safe to operate.

No one should be allowed underneath the car when the lift is in operation.

When the lift has reached the required height, it must then be set in the safety position. Employees can then set up for work.

Before the car is lowered, make sure everything is cleaned up below the car, the collar, and on the ground below the cradle. The entire work area should be cleaned up.

Each week check each of the movable parts, lubricate the sliding blocks and ensure that the operating parts are lubricated and positioned properly.

Bring the lift collar to its lowest position, checking the oil in the oil tank. Make sure the tank is filled 80% of the way.

If meet any troubles unsolved please contact after-sales service department of our company or our local agency.

7. Maintenance and Care

7.1 Maintaining Cleanliness

The lift should be frequently wiped down to maintain cleanliness. Before wiping, first cut the power supply.

The work area about the lift should be swept up. If large amounts of dirt should accumulate, this will accelerate the rate of wear-and-tear on the machine and reduce its natural life span.

7.2 Regular Check-ups

7.2.1 Check the safety features of the lift every day before work. The magnets should be operating normally, the locking plate should be in position, the mounting plate of the lift collar should be free of damage, etc. If you discover something abnormal, make prompt adjustments, repairs or changes.

7.2.2 Every day, check that the space between the collar chain and the hydraulic cylinders is correct. Check if the flat-ranged chain and the nut connecting it to the collar have become loose or detached.

7.2.3 Connections to the steel cable should be normal and the cable should have proper tension.

7.3 Maintenance of the Hydraulic System

7.3.1 Cleaning, Oil Change

Three months after the first full usage of the lift, clean out the oil tank and change the oil. Once per six months afterwards, clean the hydraulic system and change the oil.

7.3.2 Replacing the Seals

After the lift has been used for a period of time, if you discover any oil leakage, make a thorough inspection. If the leakage is due to from wear of the seals, then replace parts immediately following regulations.

8. Common Problems and Solution Methods

Trouble	Cause	Solution
Generator does not work	The power source or power equipment is malfunctioning	Check the power source and other electrical components, check fuses
In working mode, the	Pistons have lost effectiveness	Fix the pistons

collar automatically lowers	Pipes are leaking oil	Change the seals and tighten the nuts on the connection
	Seals on the hydraulic cylinders have lost effectiveness	Change the seals
The hydraulic system makes abnormal sounds	The oil filter is stopped up	Clean the oil filter
	Air has entered the hydraulic system	Lift the collar to max height, keep it there for 2-3 seconds
	The space between the sliding blocks and columns are not lubricated	Add lubrication
The collar creeps when raising and lowering	The space between the sliding blocks and the columns is too narrow	Select sliding blocks that will leave between a 1.5 and 2.5mm gap between the blocks and column
The main and supplementary lift support mechanisms don't move together	The equilibrium cables are stretched out after use, losing their tension	Adjust the nut on the steel cables, adding tension

9. Important Information for the User

9.1 Important Information Regarding Purchase of the Machine

Before purchasing this lift, make sure you clearly understand the product's use, feature, safety conditions, operation adjustments, etc. If there are any quality problems during shipping, installation or maintenance, please promptly contact the manufacturing company or a specializing agency.

9.2 Quality Assurance after Opening the Product

If after opening the packaging, you notice that the product and accessories and the installation list do not match, please promptly contact the purchasing department.

9.3 Foundation

The dimensions for the foundation of this product must be in accordance with those outlined by the manufacturing factory. The cement grade should be no less than #500. Concrete strength should be no less than 250 grades. If you cannot meet these requirements for foundation strength, any problems resulting are the user's responsibility.

9.4 Important Items

Before using this product, please carefully read the operating instructions in this manual.

Turn on the power switch. The power light will go on, and then can use the machine.

In order to protect electrical components we choose DC 24V to control open locks.

10. Components Chart

The chart is only used for maintenance and after-sales service, other usage is not allowed.

10.1 Explosion list for reference

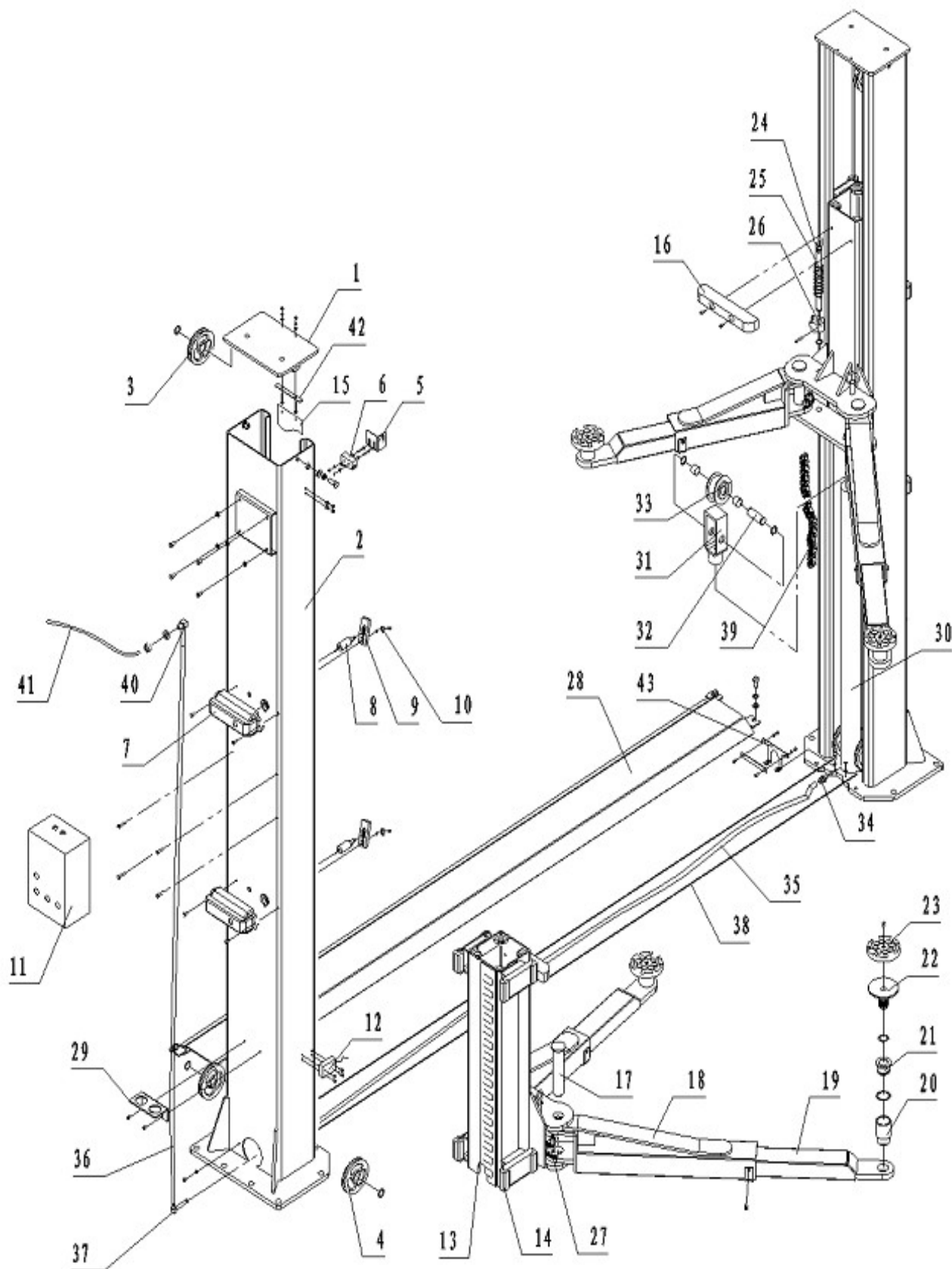

No.	Name	QTY
1	Top plate	2
2	Main column and supplementary column	1 for each

3	Rope wheel B	2
4	Rope wheel D	4
5	Support of limit switch	1
6	Limit switch 7120	1
7	Cover of magnet	4
8	Magnet	4
9	Lock plate	4
10	Block	4
11	Cover of electrical box	1
12	Limit switch ME9101	1
13	Sliding table	2
14	Sliding block	16
15	Dust prevention cover	2
16	Car door protector	2
17	Arm pin	4
18	Fixing arm	2 for each
19	Moving arm	2 for each
20	Adjustable bar	4
21	Pallets nut	4
22	Pallets	4
23	Pad	4
24	Pin of arm lock	4
25	Spring of arm lock	4
26	Teeth on sliding stand	4
27	Teeth on arms	4
28	Bottom plate assembly	1
29	Adjustable bar's carrier	2
30	Oil cylinder	2
31	Support of oil cylinder	2
32	Chain wheel pin	2
33	Chain wheel	2
34	Through joint	2
35	Long hose	1
36	Short hose	1
37	Parachute valve	1
38	Steel cable	2
39	Chains	2
40	Right-angle connector	1
41	Hose connected to pump	1
42	Hose protector	2
43	Support of dust prevention cover	2

10.2 Layout diagram(Distance of columns 2735mm/2820mm/2940mm)

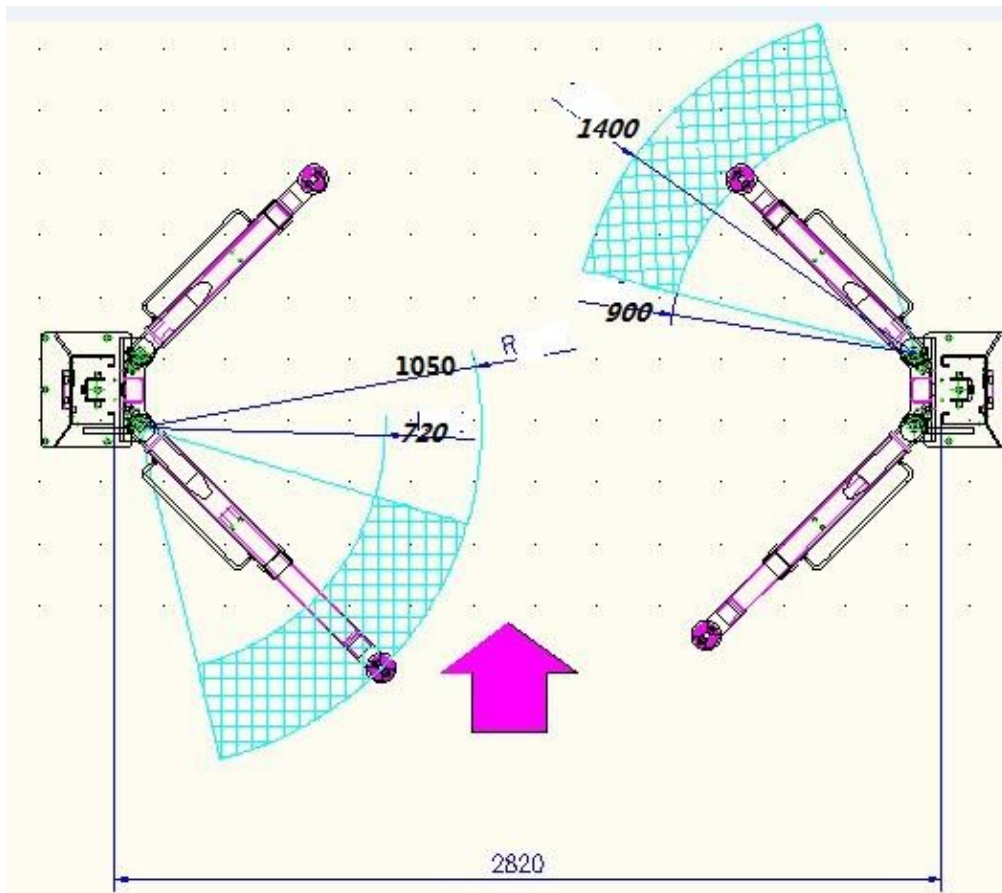
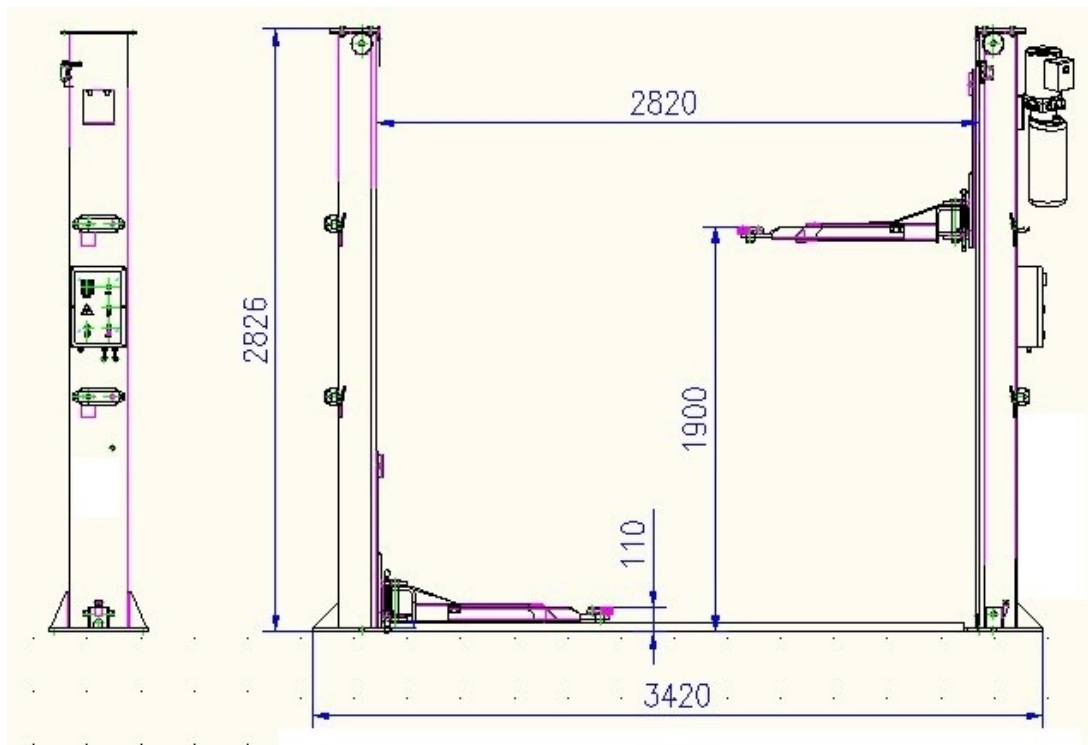

We provide 2 kinds of asymmetrical arm solution:

a) Shorter Arm length	Min.700mm- Max.1080mm
-----------------------	-----------------------

b) Longer Arm length	Min.900mm-Max.1400mm

Customer can choose a) + b) for normal cars or choose b) + c) for cars and some Vans.

10.3 Circuit diagram

Normally there are 2 kinds of power supply voltage. 220V/230V, 1Ph and 380V/400V, 3Ph

For 230V, 1Ph we provide L, N, PE in the control box for wiring.

For 380V, 3Ph we provide L1, L2, L3, N, PE in the control box for wiring.

220V, 1Ph Diagram

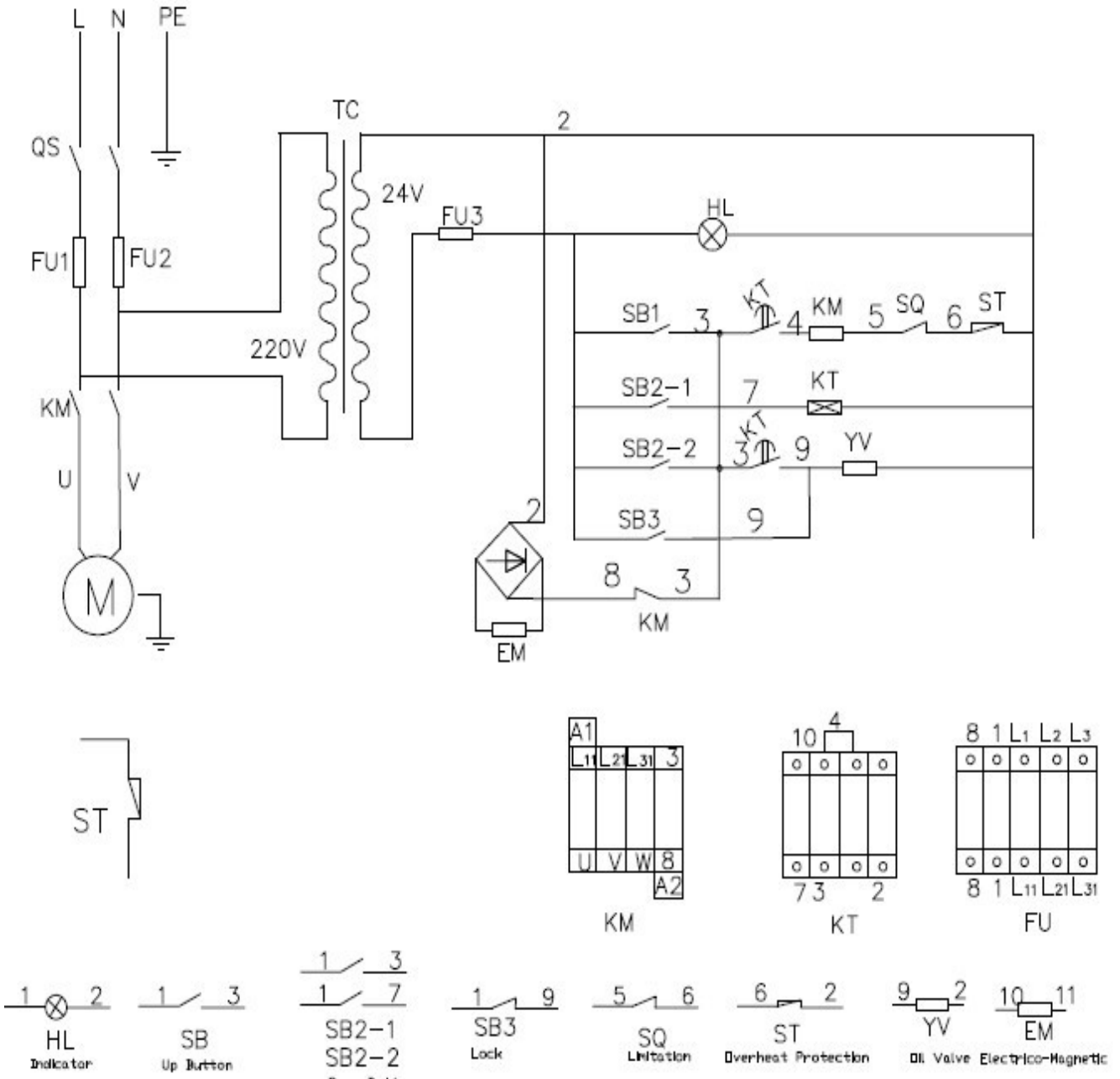

10.4 Hydraulic system



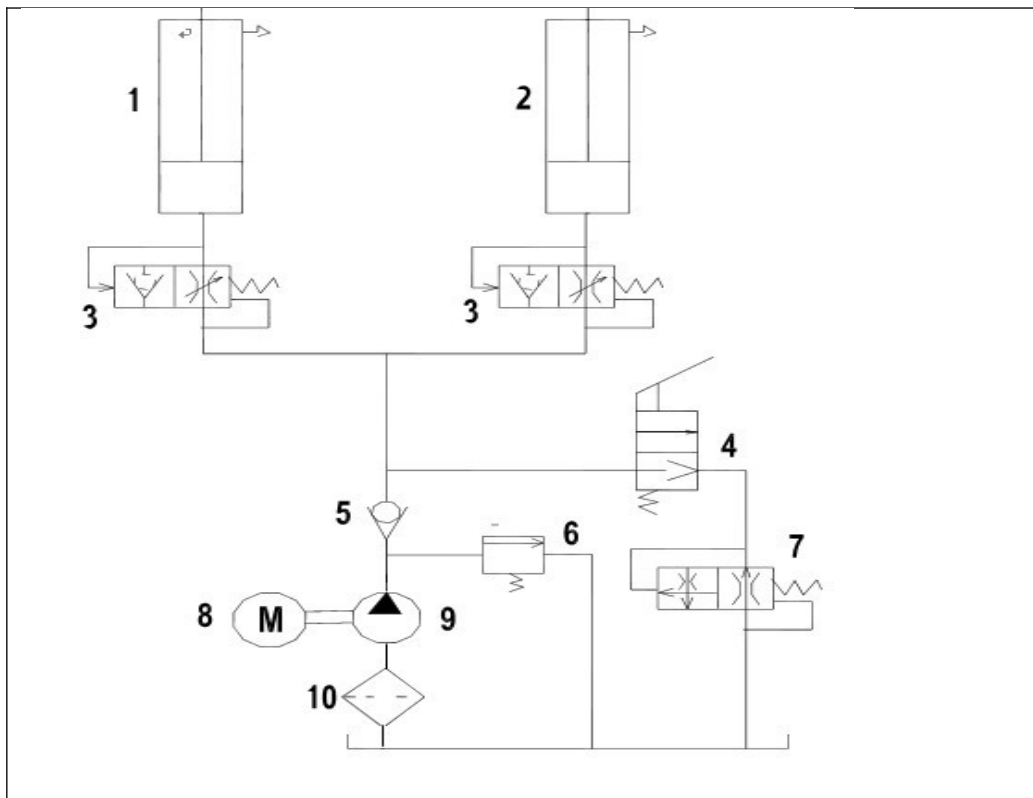

1	Master cylinder	6	Pressure Adjust valve
2	Slave cylinder	7	Lowering Speed Adjust valve
3	Anti-explosion valve	8	Motor
4	Solenoid Lowering valve	9	Gear pump
5	Non return valve	10	Oil filter

10.5 Hose Connection

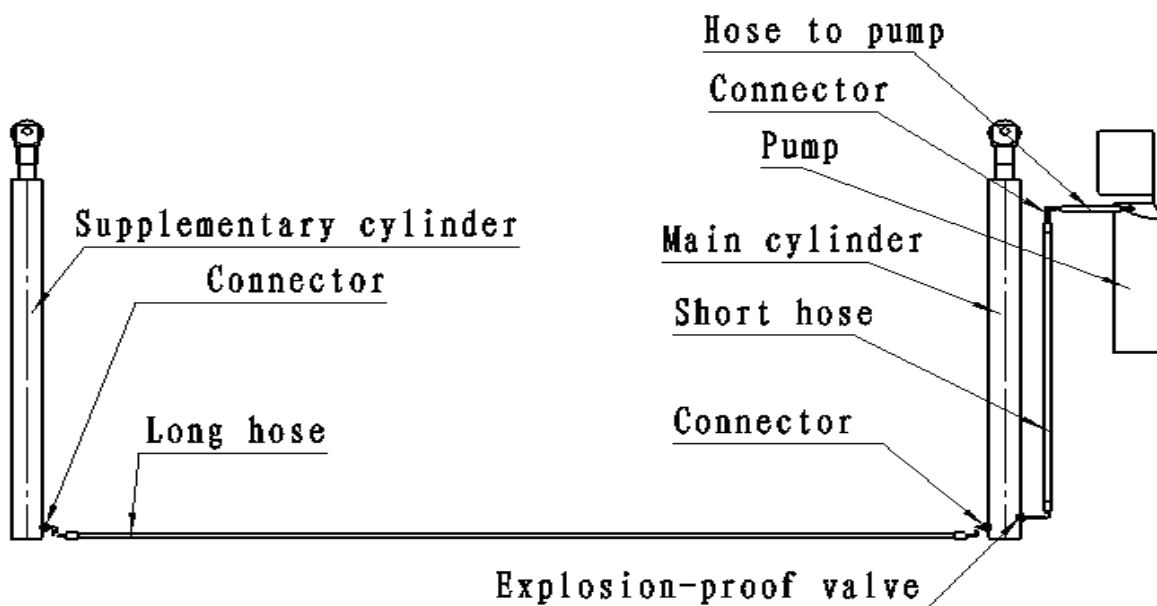

10.6 Cable System

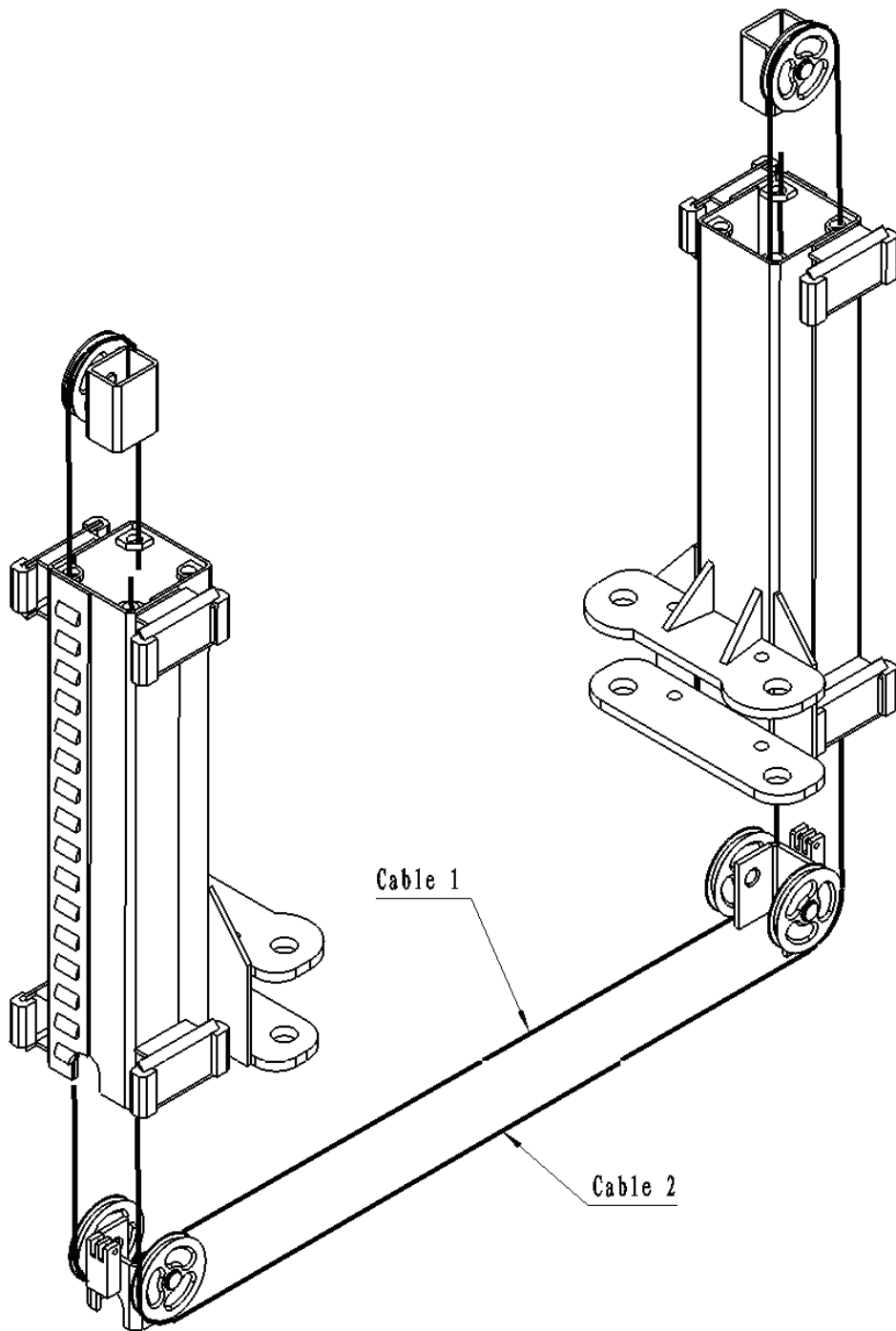

Diagram 5

10.7 Safety Lock System

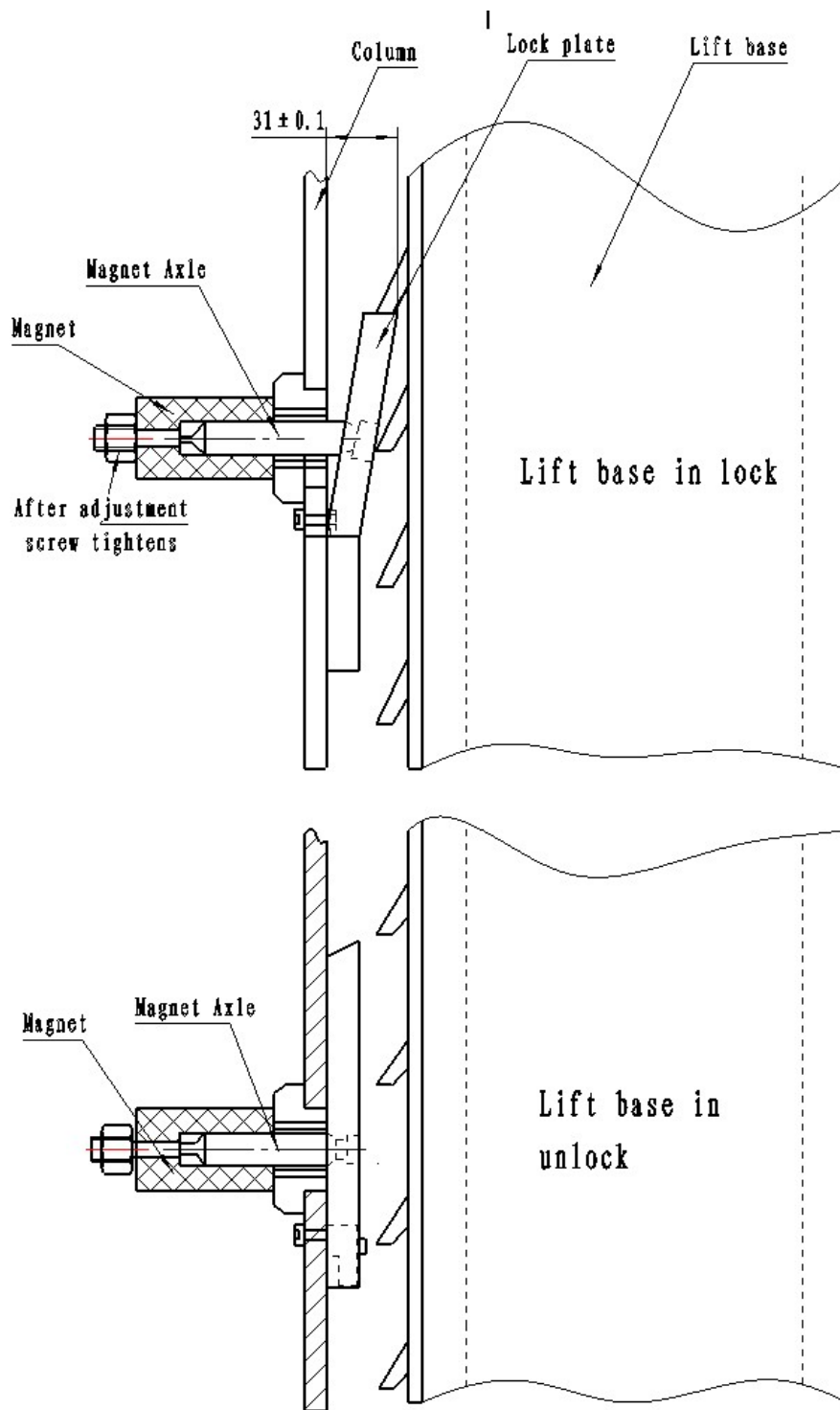
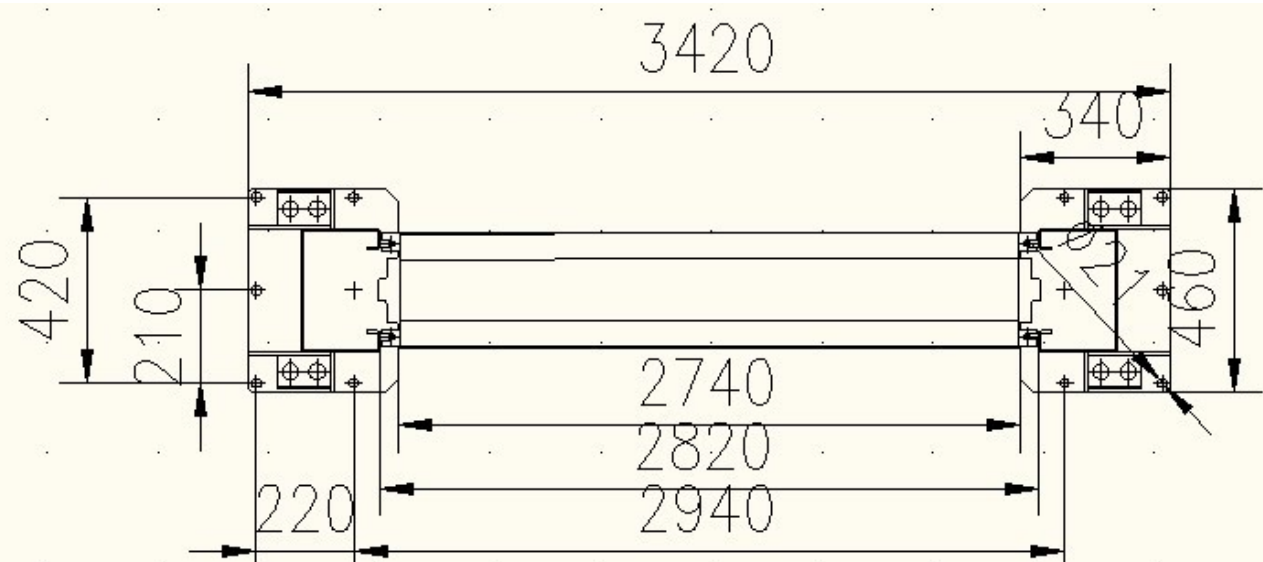
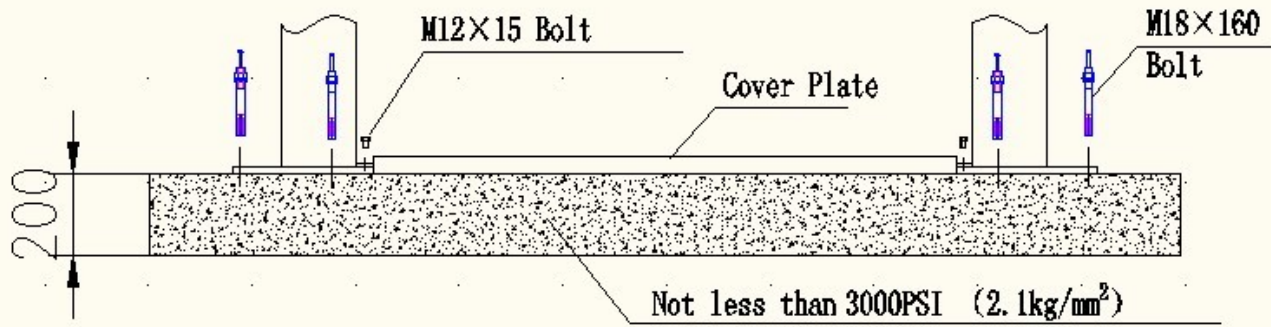

Diagram 7

10.8 Foundation

Foundation drawing is for reference. Most of the installation is done by experienced professionals.



DEKLARACJA ZGODNOŚCI

Według ISO/IEC Guide 22 i EN 45014

Producent: Foreintrade S.A

Adres producenta: Janówek, ul. modrzewiowa 54 05-555 Tarczyn

DEKLARUJEMY, ŻE PRODUKT JEST ZGODNY Z NORMAMI EUROPEJSKIMI

Nazwa Produktu: Two-column lift (oznaczona znakiem towarowym Kraft&Dele)

Model (oznaczenia handlowe): KD5815

Deklaracja:

Wyrób do którego odnosi się niniejsza deklaracja spełnia wymagania Dyrektyw WE:

1. 2006/42/EC Machinery Directive

Według norm:

EN ISO 12100:2010

EN 60204-1:2018

EN 1493:2010

Osoba odpowiedzialna za prowadzenie dokumentacji technicznej: Ma Dong Hui,

Janówek, ul. modrzewiowa 54 05-555 Tarczyn

Ma Dong Hui, Tarczyn, 01.01.2025

Foreintrade S.A
Janówek, ul. Modrzewiowa 54
05-555 Tarczyn
NIP: 521-36-70-752; Regon: 147383292



