

WHEEL BALANCER KD5840



WARNING

- This manual is an integral part of this product, pls read carefully to prevent any danger of misoperation!
- Keep this manual well for future further maintenance.
- This machine is only used for wheel balancing, not for other purposes.
- The manufacturer is not liable for damage caused by misuse or using for other purposes.

DO'S AND DONT'S

- The machine must be operated by specially trained and qualified personnel. Any modification of the machine parts and out of scope of use, without the permission of the manufacturer or the requirements of the manual, may cause direct or indirect damage to the machine.
- The balancing machine should be installed and fixed on smooth ground. Don't place it on wood floor! Otherwise the accuracy will be reduced easily!
- A distance of not less than 0.6m should be left between the back of the balancing machine and the wall to ensure good ventilation and heat dissipation. Note: leave enough space on the left and right side of the balancing machine to allow unrestricted operation.
- Do not keep the balancing machine in an extremely hot, extremely cold, or extremely humid environment. Avoid placing it next to heating equipment, faucet, air humidifier or stove, and avoid contacting with a lot of dust, ammonia, alcohol, thinner or spray adhesive.
- When operating, please use appropriate equipment and tools, and wear corresponding labor protection supplies, such as: work clothes, goggles, safety shoes.
- When the machine is working, please keep it away from the non-operator. Please be careful not to touch the moving parts with hands or other parts of the body when the balancing machine is working.

TABLE OF CONTENTS

1.	overview-----	
	----1	
2.	installation -----	
	-----4	
3.	machine	
	introduction-----	5
4.	operation -----	
	----7	

5. calibration -----	
----13	
6. trouble description	
-----	15
7. trouble	
shooting-----	16
8. parameter	
setting-----	16
9. OPT program-----	17

ONE. overview

The poor dynamic balance of wheels will make the running wheels jump and the steering wheel vibrate, which will affect the driver's driving, leading to increase gap of the joint part of the steering system, damage the shock absorber and steering parts, and increase the probability of traffic accidents. These problems can be avoided by performing the wheel balancing.

This type of wheel dynamic balancing machine adopts the new type of hardware system with large scale integrated circuit consisting of high speed information acquisition, processing and calculating. The machine is equipped with: DYN dynamic balance, ALU1 aluminum alloy, ALU2 aluminum alloy and ALU3 aluminum alloy and ALUS free paste mode (total 6 kinds of mode) to balance all kinds of car wheel shape.

1. technical indicator

- Max. wheel weight : 65kg
- Motor power : 250w
- Voltage : 110V/60HZ ~ 220v50HZ
- Balance precision : $\pm 1g$
- Balance speed : about 200r/min
- 1 standard mode, 6 aluminum alloy balance mode
- balance cycle : 8s
- rim diameter : 10 " ~ 24 "
- rim width: 1,5"-20"
- space left at back : <240mm¹
- noise : less than 70db
- net weight : 80kg with hood: 88kg

2. performance

- in Alu mode, you can select 12 o'clock position or 6 o'clock position to paste the balance weights
- multiple balance operation modes can realize unbalanced weight clamping, pasting, etc.
- automatic trouble diagnosis and protection function.
- it is suitable for a variety of rim of steel structure and the aluminum alloy structure.
- it is **optional** about function of grating automatic measuring ruler, which can automatically measure the value of A \ D rim.
- it is **optional** about function about laser, which can indicate the position of sticking weights.
- the motor locking function is **optional**, which is convenient for lead block point finding and rim segmentation.

3. working environment

- environment temperature : -5 ~ 50°C
- altitude : ≤4000 米
- relative humidity : ≤85%

TWO.Installation

1.unpacking inspection

Check whether the parts are missing or damaged according to the packing list. If you have any questions, please contact the supplier in time. The list details are as follows :

No.	name	quantity
1	caliper	1
2	#1 cone	1
	#2 cone	1
	#3 cone	1
	#4 cone	1
3	quick nut	1
4	lead screw	1
5	reverse positioning bowl	1
6	reverse positioning bowl cushion	1
7	balance hammer	1
8	100g balance lead	1

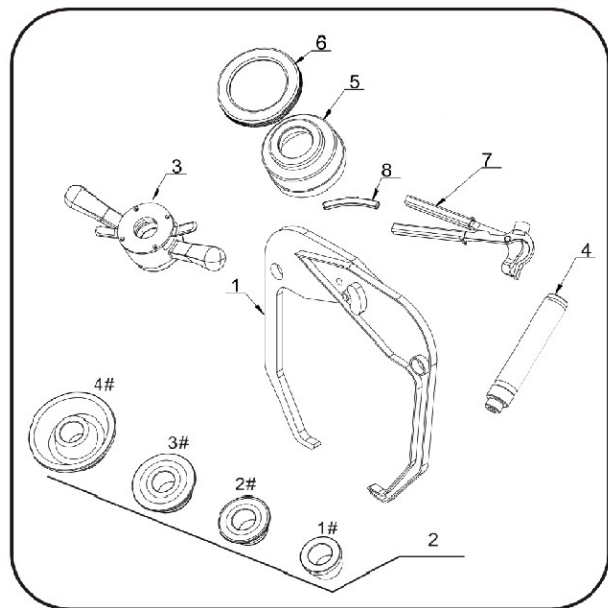

2.machine installation

The equipment must be installed on a solid cement floor or similar. If the ground is not solid, measurement error will be caused. There should be space around the equipment for easy operation.

See below:

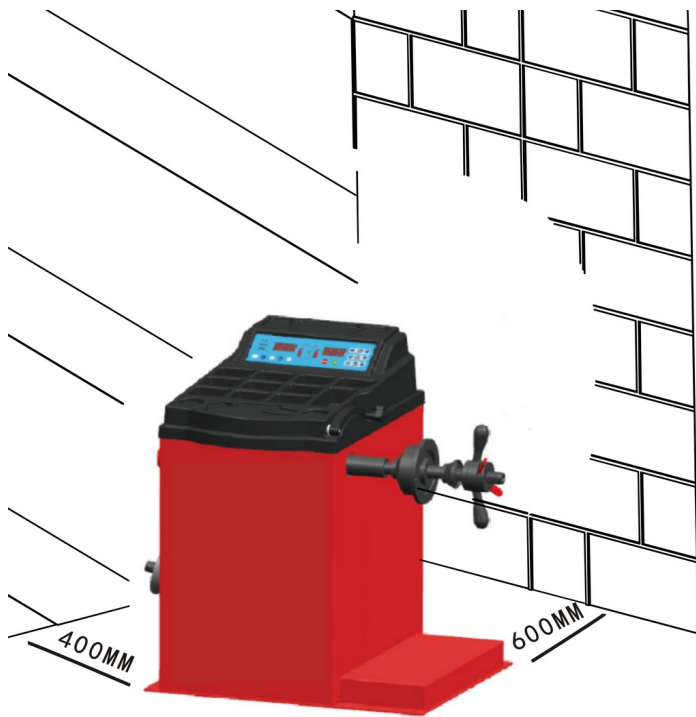

Note: This figure does not represent the actual shape of the equipment you purchased, this figure is for the installation location reference only.

3. The position of the mounting hole of the machine base should be fixed by expansion screw.
4. main shaft screw installation

Install the equipped screw on the main shaft, and tighten it (see below picture)

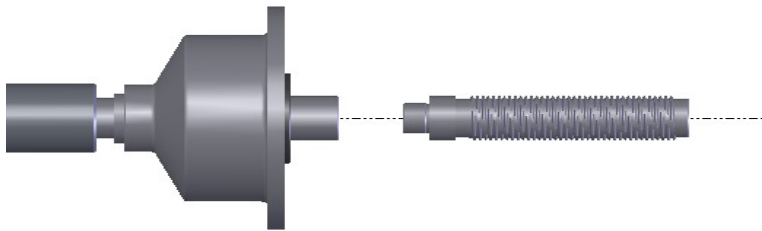

Note: when installing and removing the wheels, do not allow the wheels to slide on the main shaft screw to avoid scratches.



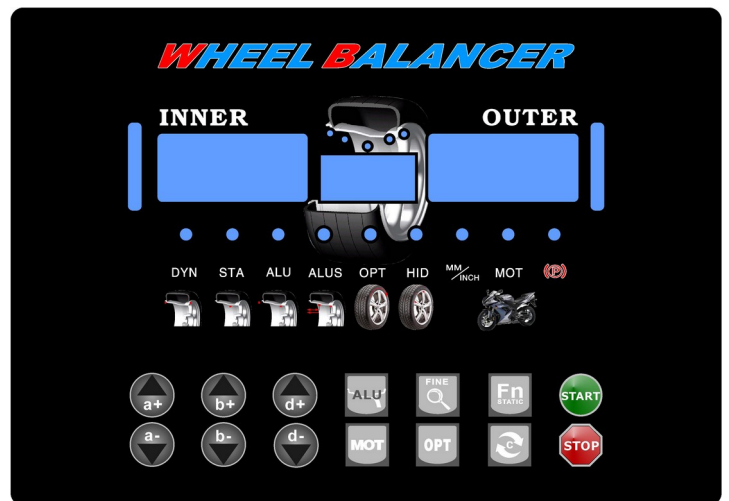

- 1
- 2
- 6
- 3
- 4
- 5

THREE .machine introduction

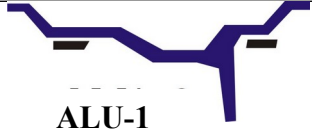
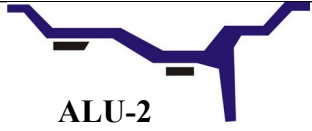
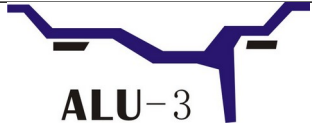
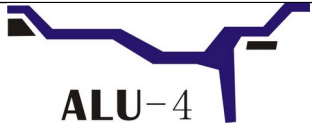

display window (G)







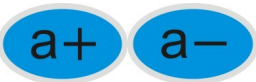

1. display inner unbalance position indication stripe
2. display unbalance value inner
3. display unbalance value outer
4. display outer unbalance position indication stripe
5. balance mode indicator , it can realize the following balance mode:
6. ALU mode selection indicator

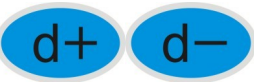
figure	balance mode	operation method	explanation
 DYN	standard balance mode	<ol style="list-style-type: none"> 1. turn on the machine 2. input a,b,d value 3. start, wait until it stops 	The unbalance weights is clipped on the alignment planes at the two edges of the rim
 ALU-1	ALU1 balance mode	<ol style="list-style-type: none"> 1. turn on the machine 4. input a,b,d value 5. Press the ALU key to turn on the mode light 6. start, wait until it stops 	An unbalanced weights is pasted on the two alignment planes inner and outer side of spoke the rim
 ALU-2	ALU2 balance mode	<ol style="list-style-type: none"> 1. turn on the machine 2. input a,b,d value 3. Press the ALU key to turn on the mode light 4. start, wait until it stops 	Clip the unbalanced weights on the alignment plane inner, and paste the unbalanced weights at outer.
 ALU-3	ALU3 balance mode	<ol style="list-style-type: none"> 1. turn on the machine 2. input a,b,d value 3. press the ALU key to turn on the mode light 4. start,wait until it stops 	An unbalance weights is pasted on two alignment planes inside and outside spokes of the rim
 ALU-4	ALU4 balance mode	<ol style="list-style-type: none"> 1. turn on the machine 2.input a,b,d value 3. press the ALU key to turn on the mode light 4. start, wait until it stops 	Clip the unbalanced weights on the alignment plane inner, and paste the unbalanced block at outer.
 ALU-5	ALU5 balance mode	<ol style="list-style-type: none"> 1. turn on the machine 2.input a,b,d value 3. press the ALU key to turn on the mode light 4. start, wait until it stops 	paste the unbalanced weights on the alignment plane inner, and clip the unbalanced weights at outer.
 ALU-S	ALUS balance mode	<ol style="list-style-type: none"> 1. turn on the machine 2. press the ALU key to turn on the mode light 3. input ①ai②ae③ d value 4. start,wait until it stops. 	Paste unbalance weights on two correction planes inner and outer sides of the spokes of the specified rim
 ST	Static balance mode (motor cycle)	<ol style="list-style-type: none"> 1.turn on the machine 2.input a,b,d value 3. press the ALU key to alive the mode 4. start, wait until it stops 	Paste unbalance weights at center of wheel rim on alignment plane

Pressbutton function (H)

figure	function description	figure	function description
	distance caliper head to the inner rim		OPT program
	input tire width		balance mode slection

			
	input tire diameter		combination/division
	recalculate the balance results		display actual unbalance value
	start		stop or cancel

Four.operation

1 · Standard balance mode

1) install the wheel

★ Befor perform any operation make sure to remove all counterweight. Check whether the tire pressure conform to specified value. Check if there is any deformation on rim locating surface and mounting hole. According to the wheel rim structure, select the appropriate tire installation method. Choose the following two installation methods according to the wheel rim structure:



main shaft— (direction of the rim installation surface is inside) — suitable cone (small side inside) —quick nut

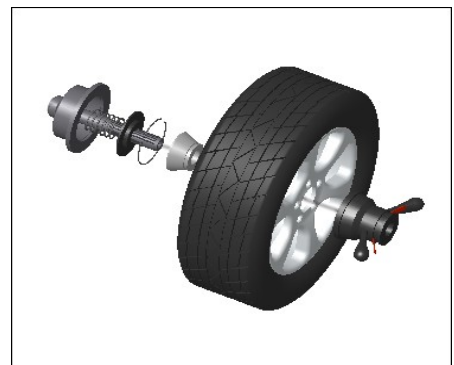





main shaft—tower spring— suitable cone (big side inside) —wheel—quick nut

Note : when install or remove the wheel,it is not allowed to slide the wheel on main shaft screw,to avoid any scratching.

2) turn on the power switch

3) input a b d value **(Automatic measuring ruler is optional)** If there is no automatic ruler, please enter it manually

- distance (a) value : pull the scale to the position as in pic.1 and hold it for 4 seconds, read this value from measuring scale, and input the value manually through  .
- width (b) value : read it directly from the rim or measure it by equipped caliper as in pic.2, and input the value manually through  .

- diameter (d) value : read it directly from the rim, and input the value manually through **d+** **d-**

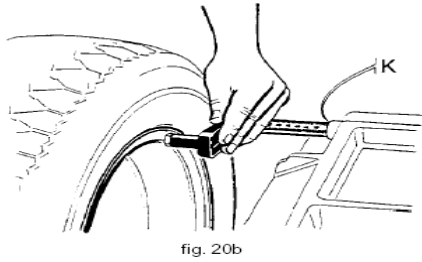

Pic.1

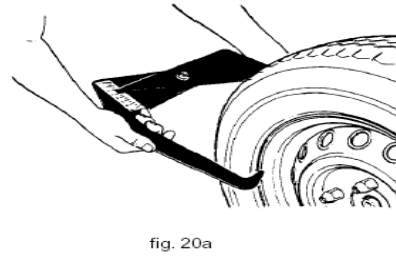

Pic.2

4) put down the hood or press **START** key to rotate the wheel

5) After the wheel stops, the digital tube displays unbalanced weight , press **FINE** key to read actual unbalance weight.

6) Slowly rotate the tire counterclockwise by hand until the indicator light outer is all on. At this time, the highest point (12 o'clock) of the outer rim is the correct point of the unbalance. Add corresponding weights at this position. See Pic.3

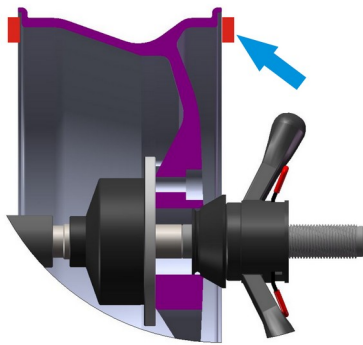

Pic.3

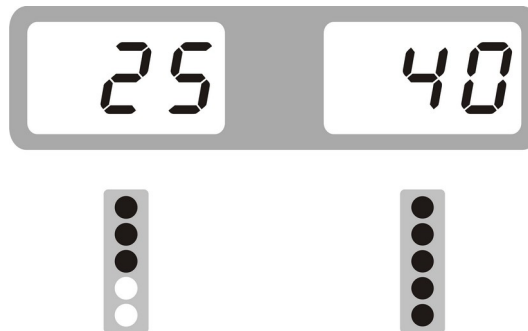

7) Slowly rotate the tire counterclockwise by hand until the indicator light inner is all on. At this point, the highest point (12 o'clock) on the inner rim is the correct point of unbalance. Add corresponding weights at this position. See

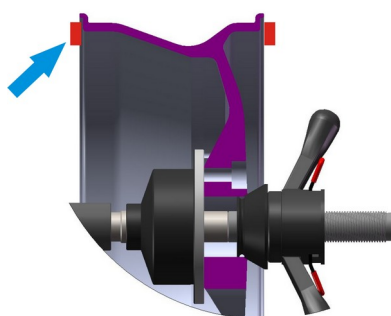

pic. 4

Pic.4

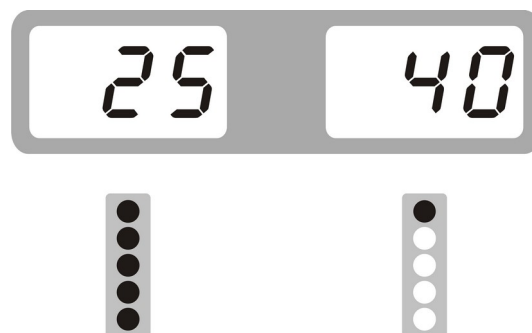

8) After the weight lead is all placed on , press **START** key to rotate the wheel , if no mistake during operation, pic. 5 will be shown, which indicates that the dynamic balance is successful





Pic.5

2 . ALU-2 balance mode (stick weights on the rim)(ALU-1 , ALU-3 are the same, only different position)

1) Pls. refer to the above mentioned way of measuring a、 b、 d, three values.

2) According to shape of rim, press  key to light on ALU2.

3) Pls. put down the hood or press  key to rotate the tire.

4) After the wheel stops, the digital tube displays the unbalanced weight , press  key to check the actual unbalanced weight.

5) turn the tires slowly Anti-clockwise with the hand, until the lateral imbalance indicator lights are all on, at the point at 12 o'clock(12H is off) or 9 o'clock(9H is on) are the position for unbalance point of alignment planes. Balance alignment planes are as shown in below pictures. Paste corresponding balance weight on the outside of the wheel rim. See pic.6.

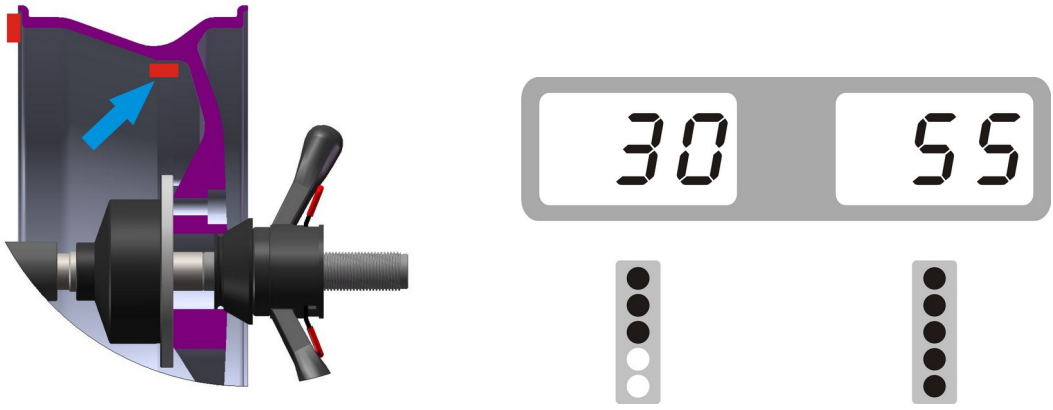

Pic.6

6) turns slowly the tires counterclockwise, until the inner side of the indicator lights are all on, at the point at 12 o'clock(12H is off) or 9 o'clock (9H is on) are the unbalance point of alignment planes. Balance alignment planes are as shown in below pictures. Paste corresponding balance weight on the inside of the wheel rim. See pic.7.

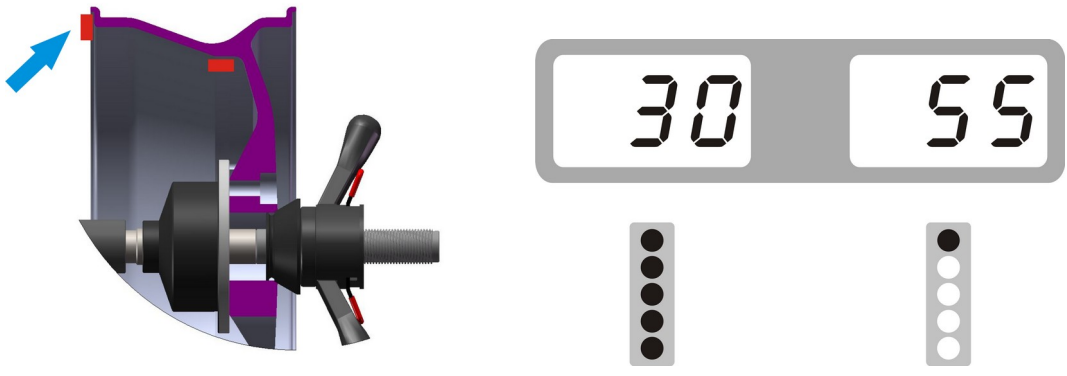

Pic.7

7) After placing the balanced lead, press  key to rotate the wheel. If the operation is correct,we will see pic. 8. It indicates that the balancing was successful.



Pic.8

3 . ALU – S balance mode (Automatic measuring ruler is optional) If there is no automatic ruler, please enter it manually (Automatic measuring ruler is optional) If there is no automatic ruler, please enter it manually

★This function is applicable to very special rims, and the normal alu-1 and alu-2 methods can't guarantee sufficient balance accuracy. Choose this balance mode.

1) Input al, aE, d value

- al distance" value: Pull out the ruler head as it is shown in pic. 9 first and hold it at F1 position for 4 seconds, automatically read the "al distance" data from the measuring ruler manually correct the data through input **a+** **a-** (automatic measurement is optional)
- AE distance " value: pull out ruler head as it is shown in pic. 9 first and hold it at FE position for 4 seconds, and automatically read the" aE distance "data from the measurement scale , and manually correct the data through input **b+** **b-** (automatic measurement is optional).
- diameter (d) value : automatically read it from the rim , input through **d+** **d-**

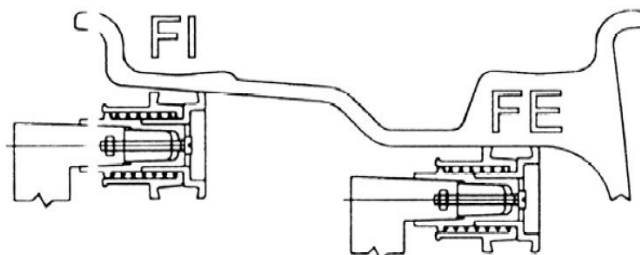

Pic.9

2) put down the hood and press **START** key , then the main shaft start to rotate

3) Unbalanced results can be operated in two ways

3.1 Rotate slowly the tire anticlockwise by hand until the outer side of indicator lights are all on , at the point of 12 O'clock is the unbalance point of alignment plane. Balance alignment planes are as shown in below pictures. Paste corresponding balance weights on the outside of the wheel rim. See pic.10

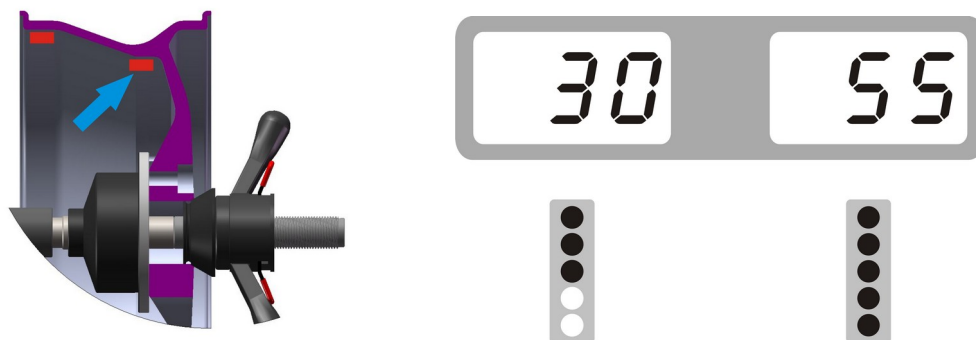

Pic.10

3.3 Rotate slowly the tire anticlockwise by hand until the inner side of indicator lights are all on , at the point of 12 O'clock is the unbalance point of alignment plane. Balance alignment planes are as shown in below pictures. Paste corresponding balance weights on the inside of the wheel rim. See pic.11

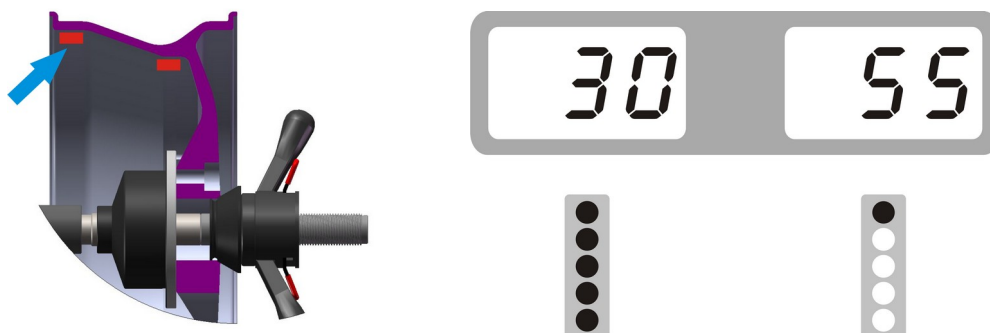

Pic.11

3.4 After placing the balanced lead, press **START** key to rotate the main shaft. If the operation is

correct, we will see pic. 12. It indicates that the balancing was successful.



Pic.12

5. if there equipped with automatic measuring ruller function, you can use the pulling ruler head to find some position to paste the weights

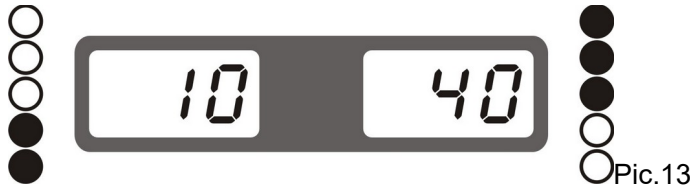

Pic.13

4.1 rotate slowly the tire anticlockwise by hand until the outside of indicator lights are all on (Pic.14) ,

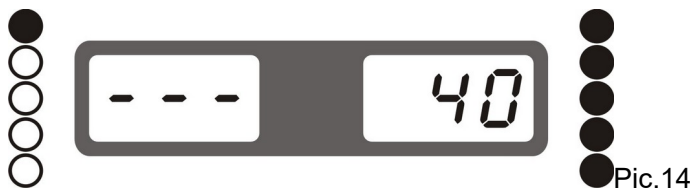

Pic.14

4.2 Tear out the suitable weight lead(Pic.15) and place it on head of ruler (Pic.16) ,

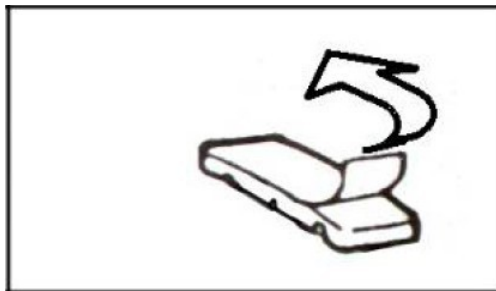

Pic.15

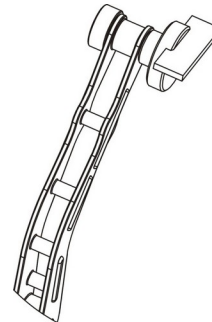

Pic.16

4.3 Pull out the ruler until to see the position of outer unbalance point on rim outside(Pic.17)

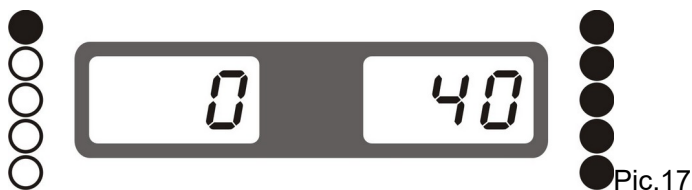

Pic.17

4.4 Paste the lead at the unbalanced point of outer rim, pic.18.

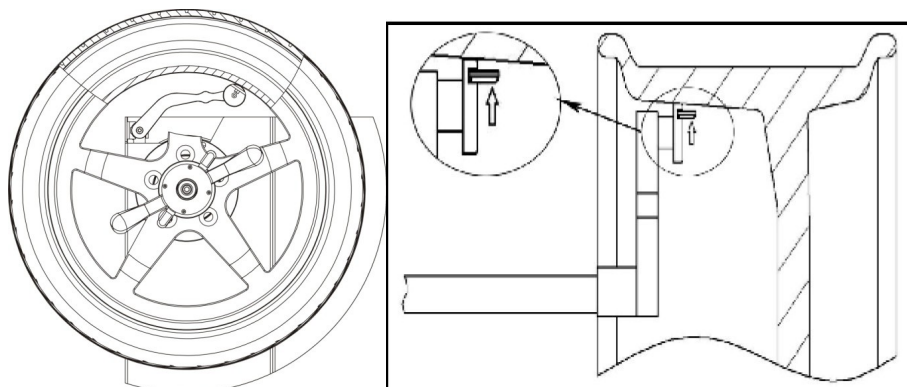

Pic.18

4.5 Rotate slowly the tire anticlockwise by hand until the inside of indicators lights are all on (Pic.19)

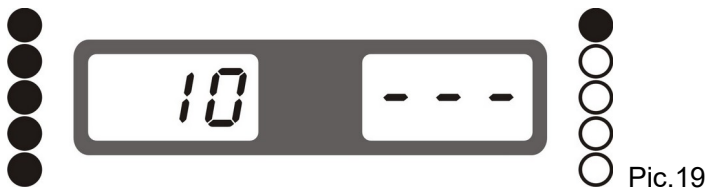

Pic.19

4.6 Tear out the suitable weight lead(Pic.15) and place it on head of ruler (Pic.16)) , pull out the ruler until to see the position of inner unbalance point on rim inside (Pic.20)



Pic.20

4.7 Paste the weight lead on the tire,Pic.21

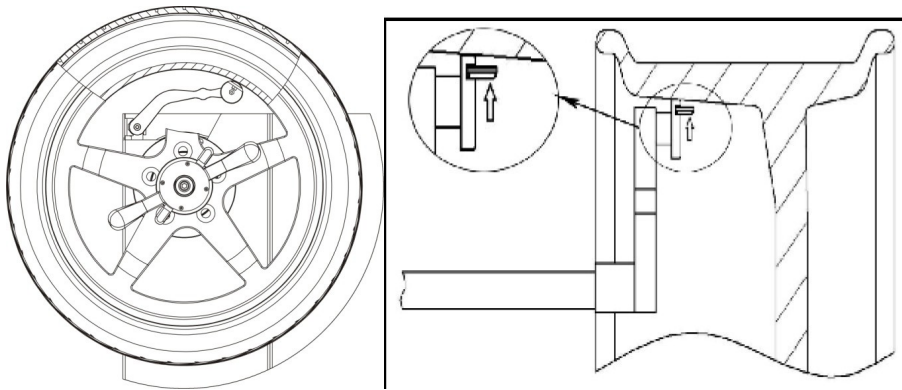

Pic.21

4.8 After placing the weight lead , press **START** key or put down the hood,pic.22 is shown. It indicates that the balancing is successful.









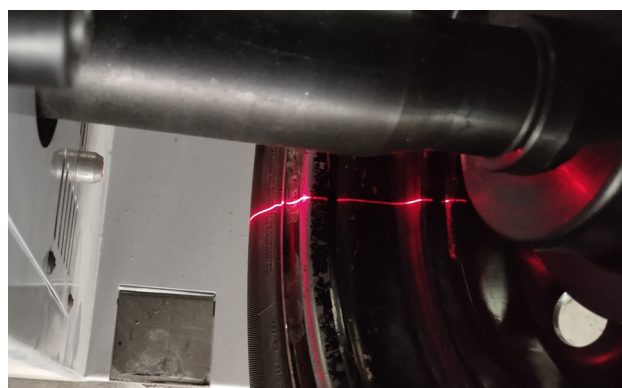





Pic.22

Note: The laser function (optional)

If the device is equipped with laser positioning function, when the laser function is on and AIU-S function is used, the position of the counterweight weights shall be at the "six o'clock" position of the rim (directly below the shaft), namely the corresponding two positions (inner and outer)indicated by the laser line. At this time, the ruler cannot be used to paste the weights (as shown in the figure).



5.ALU – S balance split operation









1	In case of ALU-S mode unbalanced weight is come out , press 	display >	
2	Input quantity of spokes by   , then press 	display >	
3	Hold one of the spokes on the rim at 12 O'clock , then press 	display >	
4	Slowly turn the tire counterclockwise until the outer side of unbalanced SP1 indicator lights are all on (the unbalanced position is determined according to SLC setting before operation)	display >	
5	Slowly turn the tire counterclockwise until the outer side of unbalanced SP2 indicator lights are all on (the unbalanced position is determined according to SLC setting before operation)	display >	
6	Put down the hood , press  key to rotate the main shaft , until it stops		
The operation is successful!			

FIVE. calibration







5.weight calibration

★Note: the self-calibration procedure should be run during initial installation, using or tested unbalanced weight is suspected to be inaccurate, to ensure the accuracy of the balancing machine (Note that the 100g balance lead used for self-calibration should be accurate, otherwise it is not correct about final result and directly affects the balance precision !)

- 5 . 1 Power on and turn on the machine's power switch
- 5 . 2 Install a medium size (13 "-18") tire which can realize balance lead to be clipped on both inner and outer side of rim, input rim data





1	Press and hold  key , at the meanwhile press  key	display >	
2	Put down the hood , press  key to rotate the main shaft , wait until it stops	display >	
3	Open the hood, rotate the rim to see outer indicator lights are all on, add 100 grams of balance lead at 12 o 'clock and lower the cover , press  key to rotate main shaft, wait until it stops	display >	
4	Open the hood, rotate the rim to see inner indicator lights are all on, add 100 grams of balance lead at 12 o 'clock and lower the cover , press  key to rotate the main shaft, wait until it stops.	display >	
Self-calibration is successful !			

6 · Distance ruler calibration (optional function no automatic ruler, no calibration required)

	display >	
Pull out the ruler to zero position and press  key to confirm	display >	
Pull out the ruler to 15 position and press  key to confirm	display >	
Self-calibration is successful !		

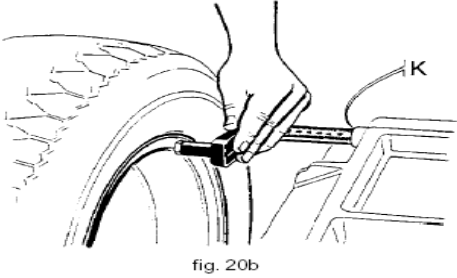

7.diameter ruler calibration (optional function no automatic ruler, no calibration required)

7 . 1 install a tire and input the diameter by   (for example,if it is 14 inch , then in put 14)

	display >	
Pull out the ruler to the rim of the tire and hold it	operate >	
Then press  key to confirm , which is indicating finished	display >	
Self-calibration is successful!		

SIX. Trouble description

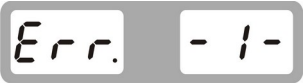
★When the machine shows the following faults, you should perform self-fault diagnosis and replace the damaged parts in time to ensure safe use !

No.	Screen displayed	Reasons	Solutions
1		1 . No rotation. 2 . With rotation.	1 . Check or replace the power panel. 2 . Check or replace the position sensor or computer panel. 3. Adjust holder of photoelectric panel
2		1 . Tire is no fastened. 2 . Position sensor.	1 . Fasten the tire. 2. Check or replace position sensor.

3		<ol style="list-style-type: none"> 1 . Tire is with no pressure. 2 . Tire distortion is out of range 	<ol style="list-style-type: none"> 1 . Mounting the tire and inflate it. 2 . Check the tire.
4		<ol style="list-style-type: none"> 1. Position sensor is something wrong. 2. Computer board is something wrong. 	<ol style="list-style-type: none"> 1. Check or replace position sensor 2. Check or replace computer board
5		<ol style="list-style-type: none"> 1 . Travel switch is something wrong. 2. Computer board is something wrong. 	<ol style="list-style-type: none"> 1. Check or replace travel switch. 2. Check or replace computer board
6		<ol style="list-style-type: none"> 1 . Power board is something wrong. 2 . Computer board I is something wrong. 	<ol style="list-style-type: none"> 1. Check or replace power board 2. Check or replace computer board
7		<ol style="list-style-type: none"> 1. Customer data lost. 2. Computer board is something wrong. 	<ol style="list-style-type: none"> 1. Self-calibration again. 2. Check or replace computer board
8		<ol style="list-style-type: none"> 1. 100g weights not add after self-calibration. 2 . Computer panel is something wrong. 3 . Power panel is something wrong. 	<ol style="list-style-type: none"> 1 . Self-calibration again. 2. Check or replace computer board 3. Check or replace power board
9		<ol style="list-style-type: none"> 1 . Travel switch is something wrong. 2. Computer panel is something wrong. 	<ol style="list-style-type: none"> 1. Check or replace travel switch. 2. Check or replace computer board
10		<ol style="list-style-type: none"> 1 . Computer panel is crashed. 2 . Power panel is something wrong. 	<ol style="list-style-type: none"> 1 . Check or replace computer panel. 2. Check or replace power panel.

SEVEN. Trouble shooting

★In normal standby mode, press and at the same time to enter in , press key to perform next testing , press key to exit.

Test order	Screen displayed	Function name	Function normal definition
1		Testing start	All lights are on
2		Position sensor	Rotate main shaft, vary from 0-127
3		Distance ruler sensor (optional)	Value showed in window varies 327-335 when pull out the ruler
4		Diameter ruler sensor (optional)	Value showed in window varies 327-335 when rotate the ruler rod to the other direction
5		Width ruler sensor (optional)	Value showed in window varies 327-335 when rotate the ruler rod to the other direction
6		Pressure sensor	Value varies from 4X-4X to 6X-6X when you press the main shaft.

EIGHT. Parameter setup

1 . Operation setup



★in normal standby mode, press key, at meanwhile press key to enter in , and are

used for amending , **a+** key is for next item.

★The machine has the following functions, which can be adjusted according to your own requirements.

Function sequence	Screen displayed	Function definition	option
1		Unbalanced weight hidden	5/10/15
2		Prompt tone	open/closed
3		brightness	1-8 grade
4		Inch switch	Inch open/inch closed
5		ALU- to paste at 9 O'clock	ALU mode to paste at 12 O'clock/ ALU-mode to paste at 9 O'clock
6		ALU-S mode switch to paste at ruler head	OFF is to paste at 12 O'clock , ON is to paste at ruler head
7		Very small wheel operation	OFF/ON

2.hood setup

★in normal standby mode, press , at mean time press  key, it will automatically switch between two states

★The machine has the following functions, which can be adjusted according to your own requirements.

Function sequence	Screen displayed	function	definition
1		hood	Put down hood to start
2		hood	Put down hood+  key to start

3.weight unit setup

★in normal standy mode, press , at mean time press  key, it will automatically switch between two states.

★The machine has the following functions, which can be adjusted according to your own requirements.



Function sequence	Screen displayed	function	definition
1		Weight unit	Weight results show grams
2		Weight unit	Weight results show ounces

NINE · OPT program

* This function can be performed when the unbalance weight is too big or the rim is deformed *

Select the appropriate installation mode according to the rim shape and input rim data

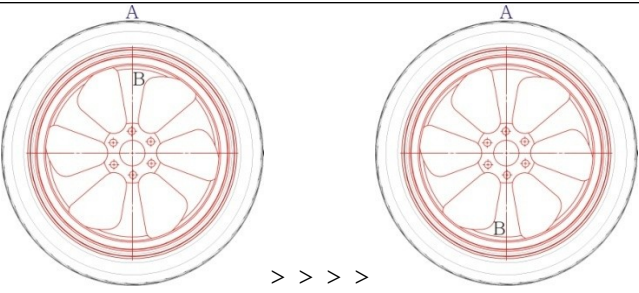
1	Press  key	display >	
---	---	-----------	--

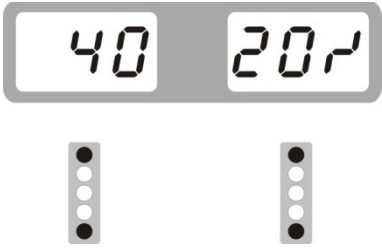
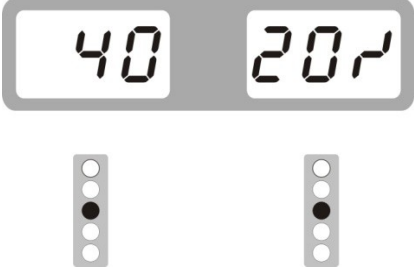
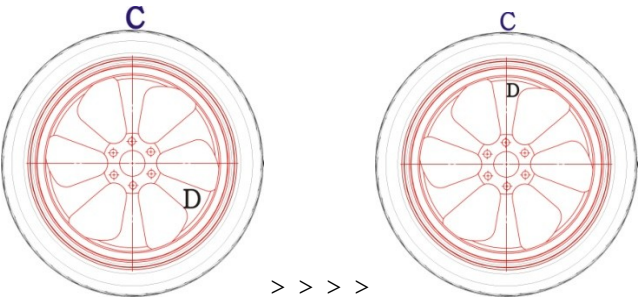
2	Put down the hood , press START key	display >	
3	Demount the tire from the rim and make a mark, then mount it again in the opposite position at 180 degree.	operate >	
4	When done, put down the hood , press START key	display >	
5	Find the rim C position and make a mark	display >	
6	Find the rim D position and make a mark	display >	
7	Make a mark at rim D and tire C, demount the tire from the rim and then mount it again to make these two points overlap with each other.	operate >	
8	When done, put down the hood , press START key	display >	Unbalanced weight is less than before is successful

DECLARATION OF CONFORMITY

According to ISO/IEC Guide 22 and EN 45014

Manufacturer: Foreintrade S.A

Manufacturer's address: Janówek, ul. Modrzewiowa 54 05-555 Tarczyn

WE DECLARE THAT THE PRODUCT IS COMPLIANT WITH EUROPEAN STANDARDS

Product name: Electric wheel balancer with laser (marked with the Kraft&Dele trademark)

Model (trade designations): KD5840

Declaration:

The product to which this declaration refers meets the requirements of EC Directives:

1. 2006/42/EC Machinery Directive

According to standards:

EN ISO 12100:2010

EN 60204-1:2018

Person responsible for maintaining technical documentation: Ma Dong Hui, Janówek, ul. Modrzewiowa 54 05-555 Tarczyn

Ma Dong Hui, Tarczyn, 01.01.2025

Foreintrade S.A
Janówek, ul. Modrzewiowa 54
05-555 Tarczyn
NIP: 521-36-70-752; Regon: 147383292



