

WHEEL BALANCER KD5842



1. FEATURES

- In case of emergency situation, press "stop" key to stop the machine
- With OPT function , optimize the matching of tire and rim
- Mm/inch, British system and G/Oz transformation

- Many kinds of balancing mode - Balancing precision $\pm 1g$, short balance time
- Failure diagnosis and self-calibration function
- HID function . to divide the balance weight and hide behind the spokes in a non-visible position
- With automatic rule function

2. TECHNICAL DATA

Wheel weight (Max.)	65kg
Rated power supply	230V/50HZ/1PH
Balancing Precision	$\pm 1g$
Rim diameter	10-24"
Rim width	1,5-20"

3 . CONTROL PANEL

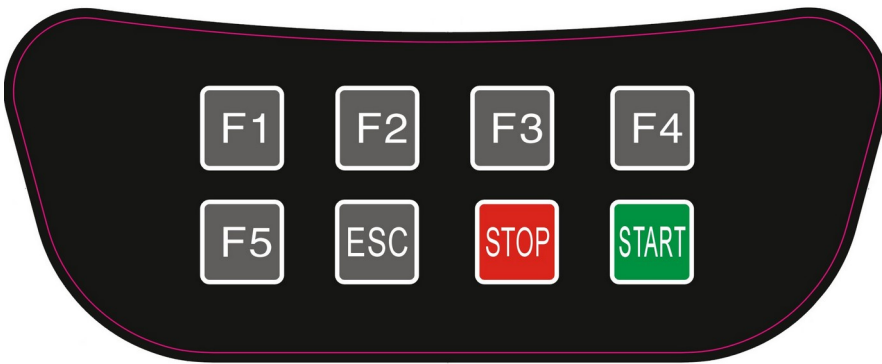

3.1 Digital meaning

F1-F5 arrows indicate the navigation confirmation keyboard

ESC The return or exit key

START Start key

STOP Emergency stop key

3.2 FUNCTION COMBINATION KEY

F1 Enter the rim data entry interface

F2 Enter the system self-test interface

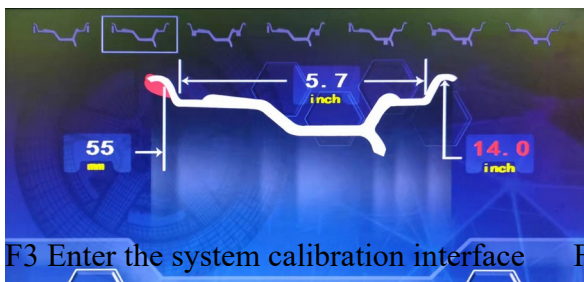

F3 Enter the system calibration interface

F4 Enter the system parameter setting interface

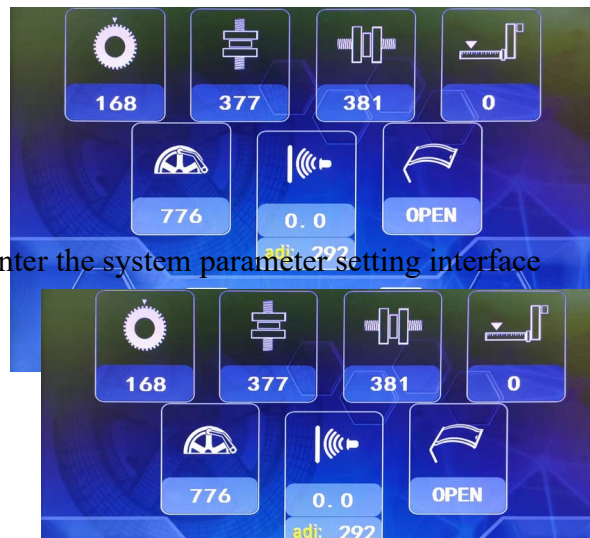

Note : Use finger to press the button , clamp or other sharp matter are prohibited.

1. Turn on display



Fig.1

2. F3 Enter the system calibration interface (Fig.2)

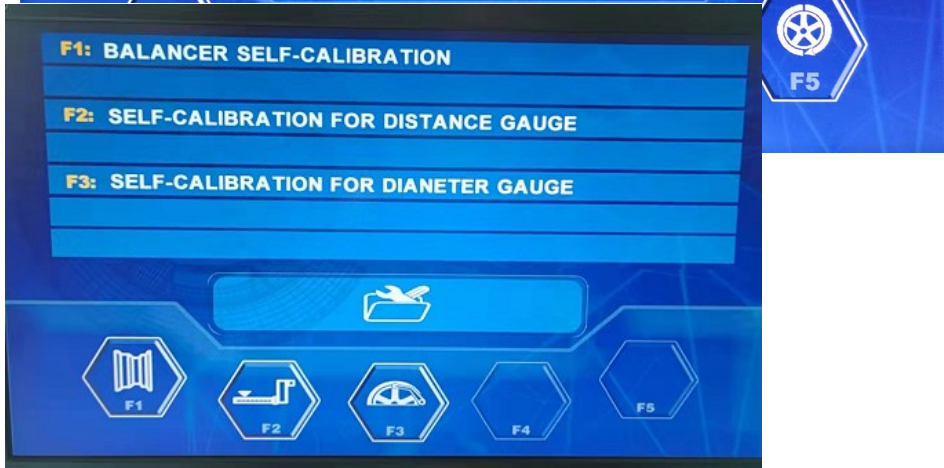

Fig.2

2.1 Press key F1-F3 exit main menu.

2.2 Get into corresponding menu ,follow the instruction to complete the functions setting.

2.3 "System self-calibration" When the balancer accuracy changes after a period of time, choose this function, as prompt steps do self-calibrated can update balancing accuracy. (Figure 3)

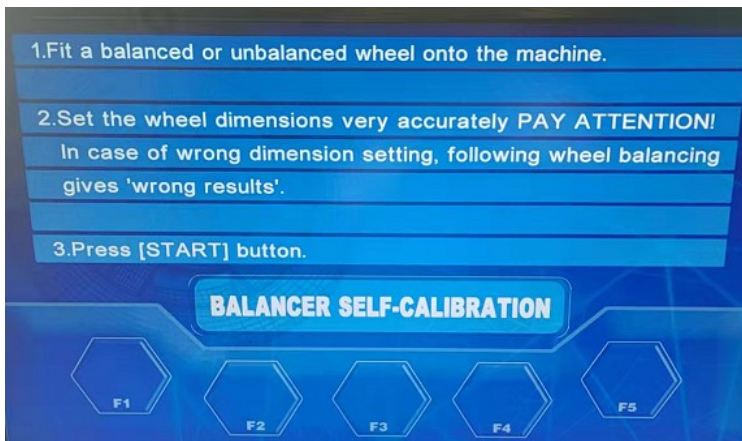

Fig.3

Follow the instruction of Figure 3 to set wheel and secure it. (It is best to calibrate with 14-15 inch steel rim) press key "START" to start

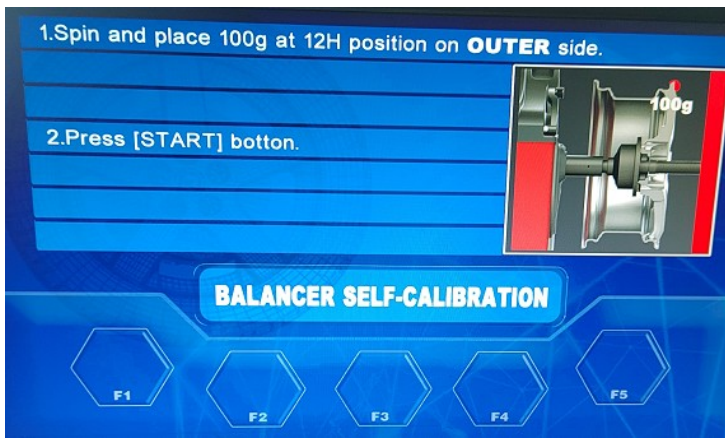

Fig.4

Follow the instruction of Figure 4, outside unbalance position is found, that is, the right red vertical bar is fully lit, in the outer 12'o clock points of the rim clip 100g weight on it, press "START"key to start

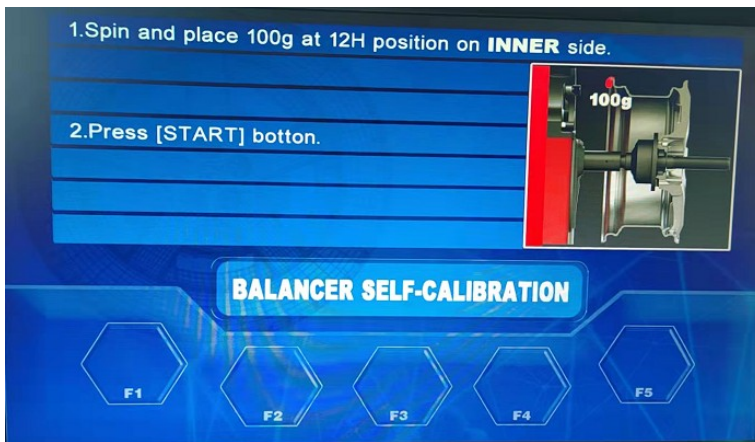

Fig.5

Follow the instruction of Figure 5, inside unbalance position is found, that is, the left red vertical bar is fully lit, in the inner 12'o clock points of the rim clip 100g weight on it, press "START"key to start

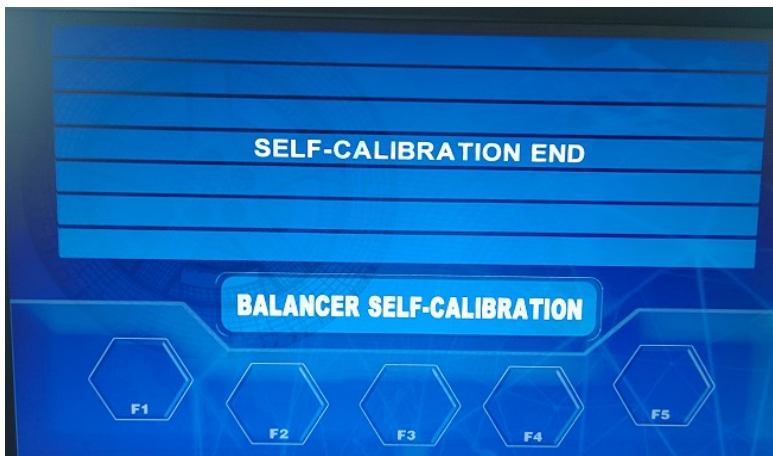

Fig.6

Figure 6, the calibration successful will prompt the calibration to complete. Repeat calibration if it fails.

Calibration finished Press ESC key return to main menu.

2.6 "A" value(distance)automatic gauge calibration:

1.As Fig 7ress key "F3"get into the gauge calibration menu(FIG.7)

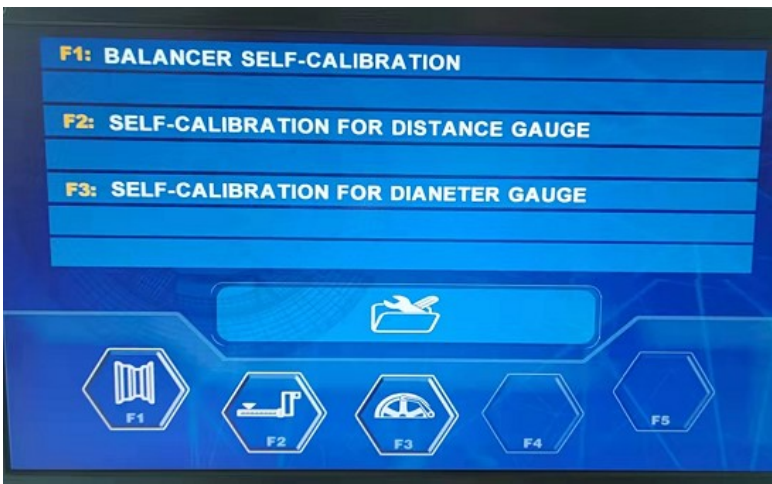

Fig.7

Follow Fig.7 ,Press Key F2, get into the“A” alvaue (DISTANCE) gauge calibration menu(FIG.8)

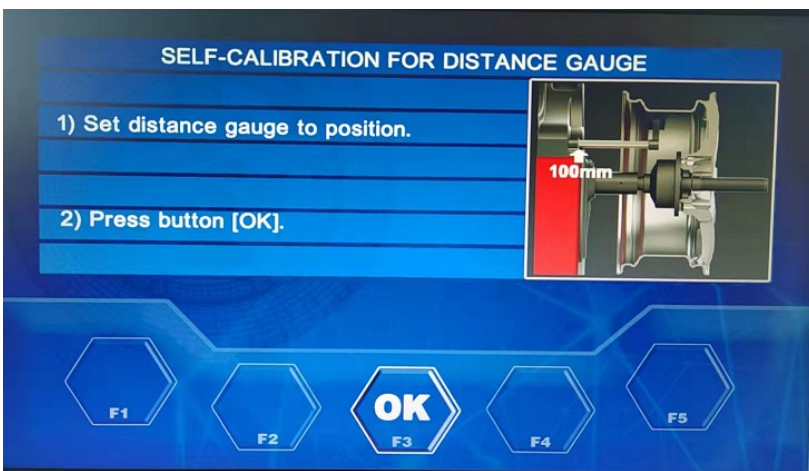

Fig.8

Pull out the gauge ,when it reaches “100”positon ,press key “F3’. Fig 9 displayed.

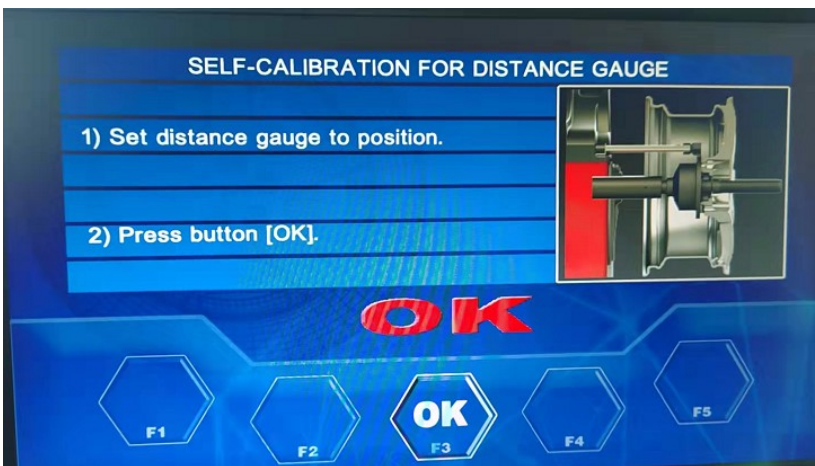

Fig.9

At this time ,Pull out gauge head reaches the inside edge of the flange on the threaded spindle, then press key “F3” show Fig. 10.waiting to prompt "OK" to put the gauge back in place, the distance gauge calibration is complete

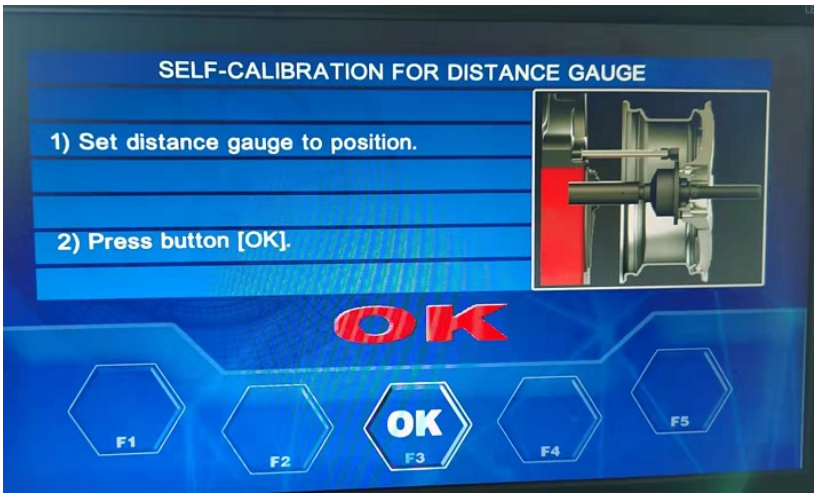

Fig.10

2.7 "Diameter automatic gauge calibration"

As FIG.2, press key "F3" get into the gauge calibration menu (FIG.7)

As FIG.7, press key "F3" get in to the Diameter gauge calibration menu.(FIG.11)

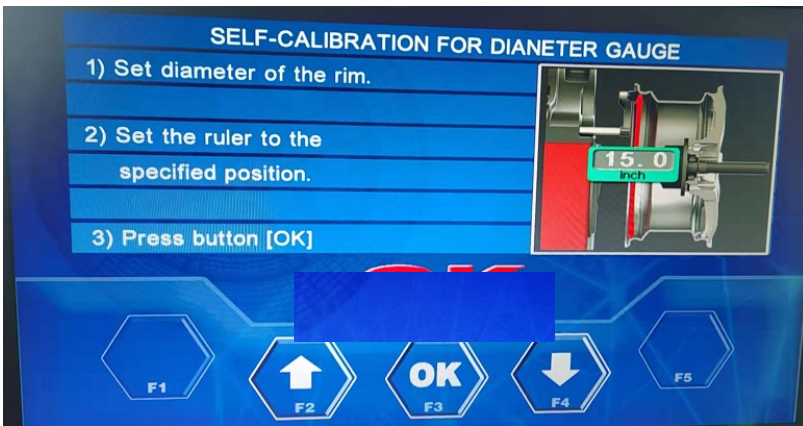

FIG.11

As shown in the picture, install the rim of the 15-inch steel rim, place the ruler on the inside side of the rim as shown in the picture, and hold it for a while. Then press "F3" button to complete the diameter calibration as shown in Figure 12.

If a 15-inch rim is not available, the actual measured rim size can be adjusted by pressing the F2 and F4 buttons according to the actual rim size.

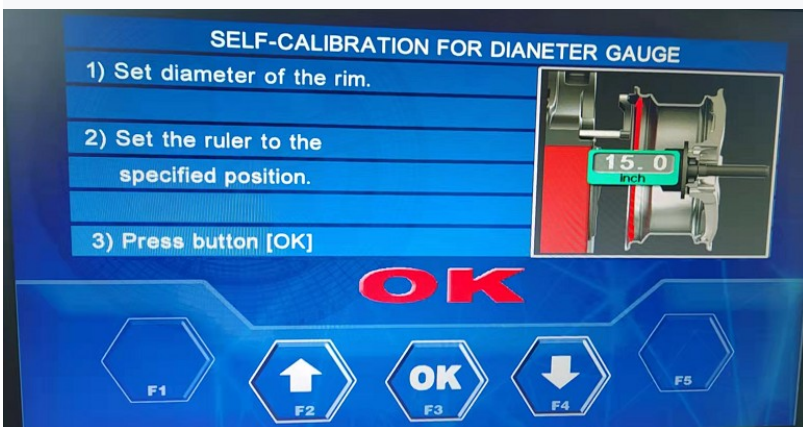

Fig.12

Note: The equipment is calibrated before leaving the factory. It can be safely used. If the accuracy is found to be inaccurate during use, the above operation can be used for calibration.

2.8 "System Self-Test"

Press F4 to enter the system self-check interface (FIG. 13)



Fig.13

This function is to detect whether the important sensors of the equipment are working normally.

3. "System Parameter Selection"

Press **F4** to enter the parameter selection interface (FIG. 14.)



Fig.14

As shown in Figure 14, the basic Settings before delivery can be adjusted according to the factory standards. If the usage habits are different from users, You can adjust according to the built-in parameters F1-F4, and press F5 key to save after adjustment.

4. Balance tyre operation process

4.1 Turn on the power and display the interface (Figure 1)

4.2 Mounting wheels

(1) Preparation before the test: check and clear the dust and soil on the tire, check whether there is metal, stone and other foreign matter on the tread; Check whether the tire pressure is in accordance with the specified value; Check whether the rim alignment surface and mounting hole are deformed, and check whether there is foreign body in the tire; Remove the original balance block.

(2) There are three types of wheel mounting, including forward positioning, reverse positioning and additional flanges for large and medium tires. A positioning method can be chosen arbitrarily according to the actual situation.

4.2.1 forward positioning



Positive positioning is a common positioning method, easy and fast operation, mainly suitable for ordinary steel ring and thin aluminum alloy ring, this positioning is suitable for the case of small deformation of steel ring.

Spindle wheel-wheel (rim mounted facing inward)- Fit cone (small head facing inward)- wheel - fast nut

4.2.2 Reverse positioning

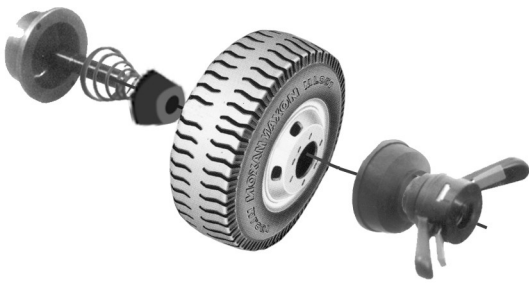

Spindle - Spring - Fit cone (head inward)- wheel - fast nut

When the lateral deformation of the wheel is large, reverse positioning is adopted to ensure the accurate positioning of the inner hole of the steel ring and the spindle. Suitable for steel ring, especially for thick

4.2.3 Positioning of special flange plate (optional accessories, not standard)



This kind of way is suitable for the wheel center hole Φ tires installed under 135.

Put together the large flange to the matcher - wheel - large cone - quick nut

Note: The cone should be chosen in accordance with the center hole of the rim, and pay attention to its direction, otherwise it will cause inaccurate measurement.

4.3 Size input

4.3 Input the size

1) Input A, B and D values (Figure 15)



Fig.15

- distance (a) data: pull the measuring ruler to the position shown in FIG. 16 for 4 seconds, automatically read the "distance" data from the measuring ruler scale, and manually correct the data by F1-F4 entering the value
- width (b) data: The "width" data can be read directly from the rim or measured using the matching calipers as shown in Figure 17, and the correct value can be entered by pressing the key F1-F4
- diameter (d) data: "diameter" data can be read directly from the rim. The correct value can be entered by pressing the key F1-F4

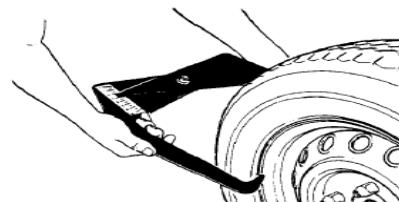
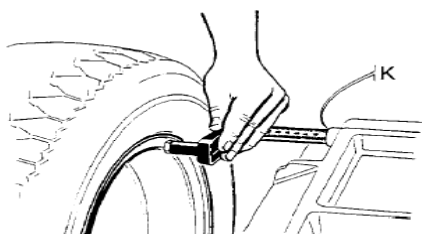

Fig.16

Fig.17



2) Lay down the protective cover or press the key to rotate the wheel

3) After the wheel stops, the screen displays the unbalanced weight. Press the button **F2** to see the actual unbalanced weight

4) Slowly rotate the tire counterclockwise by hand until the endwise indicator are all turn red, At this time, the highest point of the rim (12 o'clock) is the correction position of unbalance. Add the corresponding balance weight at this position, as shown in FIG. 18

5) Repeat the above operation on the inside to complete the unbalance calibration.



Fig.18

6) After the balancing weight is placed, press the key **START** to rotate the wheel. If the operation is correct, the state shown in Figure 19,

It will show the success of dynamic balancing



Fig.19

ALUS mode operation (do paste rim) (this system provides a variety of ALU balance modes, according to the different wheel structure to choose the corresponding balance mode)

4.4 ALU-S balance

★This function is suitable for very special rims, and adequate balance accuracy is not guaranteed using the normal ALU method. Just use this balanced mode.

1) Input values of a1, aE, d1, and de

•Data of "a1 distance" : pull out the pulling ruler and stay at the F1 position for 4 seconds as shown in FIG. 20. Automatically read the "A1 distance" data from the measuring scale and manually correct it by F1-F4 inputting the correct value in FIG. 21

•aE distance data: pull the ruler out and stay on the FE position for 4 seconds as shown in FIG. 20. Automatically read the aE distance data from the measuring scale, and manually correct it by F1-F4 inputting the correct value.

•Diameter (d1/de) data: automatically read from rim and manually correct it by F1-F4 inputting the correct value.

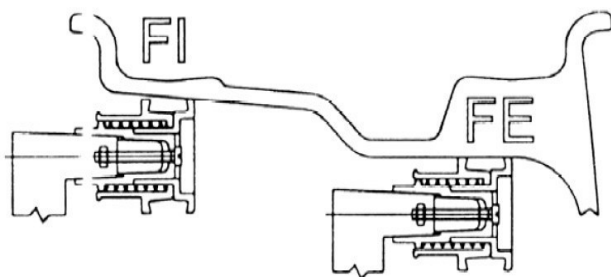

Fig.20

Fig.21

2) Lay down the protective cover or press the key **START** , and the spindle will be displayed after rotation stops as shown in Figure 22



Fig.22

3) Slowly rotate the tire counterclockwise by hand until the outside endwise indicator are all turn red (Figure 23).



Fig.23

4) Apply suitable weight (Fig.24) to the gauge head (Fig.29) .

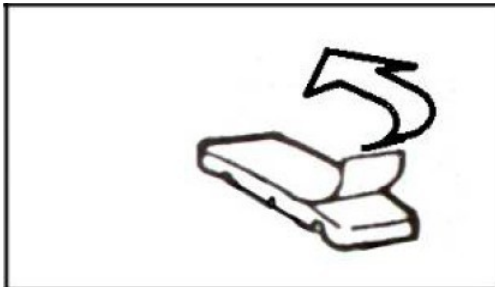

Fig.24

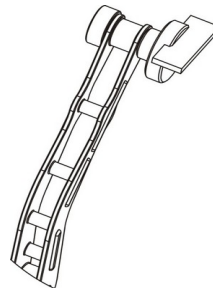

Fig.25

5) Pulling the internal gauge until read 0 displayed on the window on outer side rim, fit the weight(Fig.30)



Fig.30

6) Fit the weight to the unbalance point outer side rim(Fig.27)

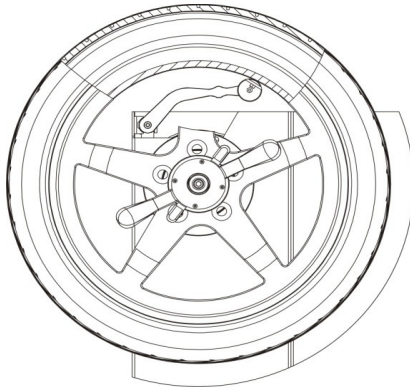
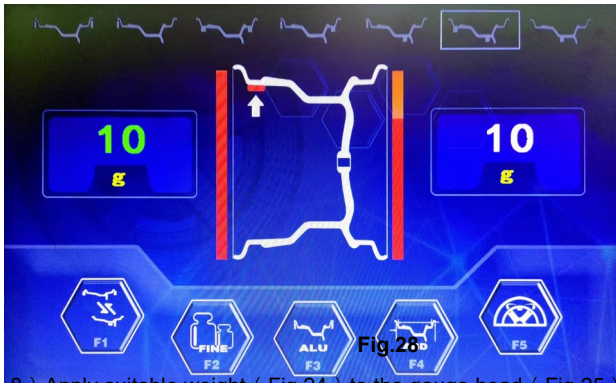

Fig.27

7) Slowly rotate the tire counterclockwise by hand until the inside endwise indicator are all turn red (Figure 28).



8) Apply suitable weight (Fig.24) to the gauge head (Fig.25) , pulling the internal gauge until a read 0 displayed on the window on inner side rim, fit the weight (Fig.29)



Fig.29

9) Fit the weight to the rim. (Fig.34)

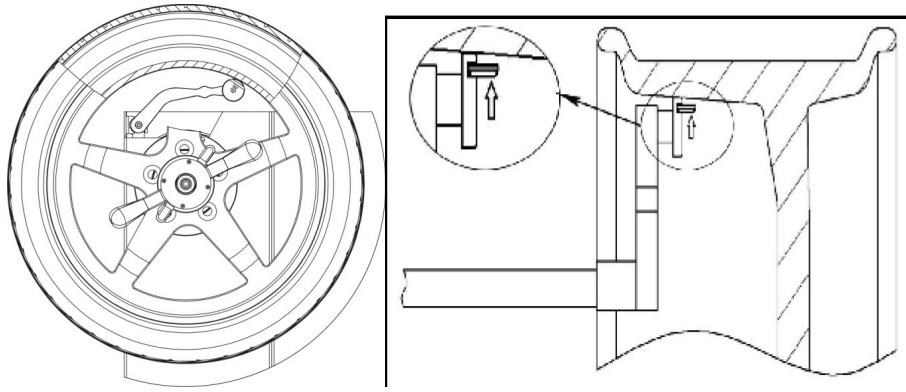

Fig.30

4.8 After apply the weight , press **START** key or put down the hood , until to see (Fig.31) ,balance finished.



Fig.31

5.ALU – S balance split operation

It is apply to ALU - S mode outer side rim, it can be used to hide the balance weight behind the rim spokes. Switch on the machine under ALU-S mode , until it stops to display (Fig.32) on the window.

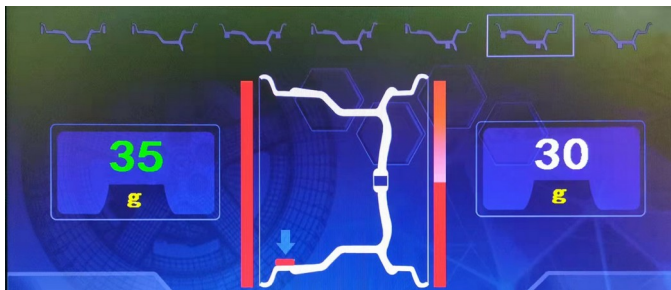

Fig.32

1) see (fig.33) press button F5, then you will see FIG.33 as below.



Fig.33

2) Fig.33 quantity of spokes input is shown on screen , press key F2-F3 to modify the value according to quantity of spokes.

3) Fig.33 screen is shown at h12 /spin one of the spokes which need to be balanced at h12, press button F 3,(Fig.34/35) is shown.

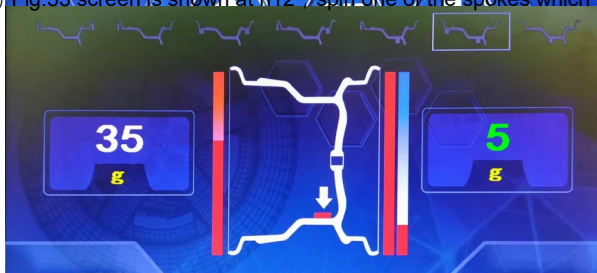

Fig.34

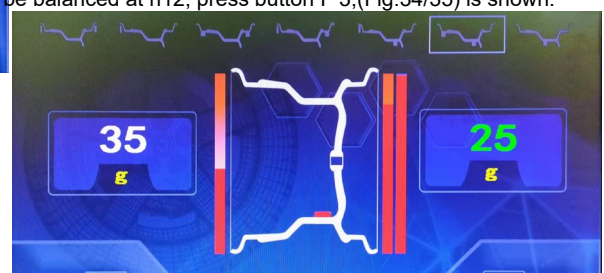

Fig.35

4) According to shown on fig.34/35 , find the two unbalanced pointes at outer side after splitted, apply suitable weights at different

unbalancing position.

5) Spin the wheel once again , to finish wheel balancing.

Note: Laser function (optional)

If the device is equipped with laser positioning function, when the laser function is on and AIU function is used, the position of the counterweight block shall be at the "six o'clock" position of the rim (directly below the shaft), namely the corresponding two positions indicated by the laser line. At this time, the ruler cannot be used to paste the lead block (as shown in the figure 36).

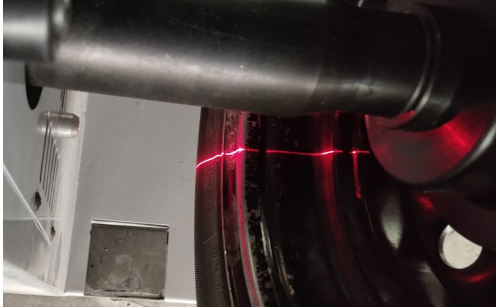

Attention

- 1. For the equipment using single phase power supply, when starting the operation push the wheel by hand one time to assist starting and prolonging service life.**
- 2 . Make sure the selected balance mode is suitable for the outline of wheel rim.**
- 3 . Make sure the lock nut is tightened.**
- 4 . Do not strike the spindle shaft when installing or removing the wheel.**
- 5 . When balancing the rim with a clip-on lead block, use a balancing weight to stick the lead block on the rim edge. After the balancing ends, strike it close on the ground. Do not strike it on the spindle shaft in order to avoid the damage of the sensor. ; To keep the adhered lead block being stuck firmly, before adhering, you must clean the adhering surface and if it is needed should use the organic solvent or detergent.**

Start no display on screen	2 . Check the switch damaged or not.	2 . Replace.
Start with buzz but no star-up, Err1 displayed	1 . Capacitor doesn't work.	1 . Replace one capacitor by 20UF/400V 2 . Check power supply.
Err-1-	1 . No stop after start. 2 . No shut off after start.	Check computer board, power board, photoelectric board.
Err2	1 . Wheel not installed. 2 . Only rim installed, not whole the wheel. 3 . Main shaft adapter not fastened. 4 . Wheel installed wrongly, not locked firmly. 5 . Belt too loose or too tight.	1 . Install the wheel and test again. 2 . Install the wheel. 3 . Fasten the lock nut. 4 . Select suitable cone and install it correctly. 5 . Readjust.
Err3	Unbalance weight too big.	Replace the wheel and test it, or self-calibration again.
Err4	1 . If spin anti-clockwise, it should be something wrong about wire connecting. 2 . Spin clockwise, means something wrong about photoelectric board.	1 . 3-phase equipment, phase-modulated is OK. 2 . Readjust position or replace it.
Err5	Hood not put down.	Put down the hood.
Err7	Memory data lost.	Self-calibration again.
Only display 00 - 00, no value	1 . Sensor lead broken or poor contact. 2 . Memory storage lost.	1 . Connect wire well. 2 . Correct memory value according to instructions.
Weight range exceed 5g after each rotation	1 . Foreign matter in tire or deformation of mounting surface of rim center.	1 . Replace the wheel. 2 . Dry it, readjust the sensor.

	<p>2 . The sensor is damp or the lock nut is not clamped.</p> <p>3 . The external power supply voltage is low or the tire pressure is insufficient, and the matcher is not locked.</p>	<p>3 . Screw the foundation bolts.</p>
<p>Weight range exceed over ten grams after each rotation.</p>	<p>1 . There is foreign matter on the wheel or the unbalance weight is too big.</p> <p>2 . Sensor is damaged.</p> <p>3 . Low voltage of external power supply.</p>	<p>1 . Change a wheel and test it.</p> <p>2 . Check sensor and wire connection.</p> <p>3 . Check and repair or install voltage regulator.</p>
<p>Non-stop time exceed 10 seconds.</p>	<p>1 . Poor grounding of external power supply.</p> <p>2 . Interference.</p>	<p>1 . Check the external power supply circuit or change a place for power to test.</p> <p>2 . Shut down and restart the machine.</p>
<p>Balancing weight is not correct, cannot reach 00.</p>	<p>1 . The sensor is damp or damaged.</p> <p>2 . Program confusion.</p>	<p>1 . Readjust it, do self-calibration after drying or replace it.</p> <p>2 . Do self-calibration again.</p>
<p>Cannot brake after value displayed.</p>	<p>1 . Brake system damage.</p> <p>2 . External interference.</p>	<p>1 . Replace the power board.</p> <p>2 . Restart and test it.</p>
<p>Tolerance between two times of dismounting exceed 10g.</p>	<p>1 . The inner hole of the wheel is irregular.</p> <p>2 . Improper installation of matcher.</p>	<p>1 . Change a wheel and test it.</p> <p>2 . Recheck surface of installation, and test it.</p>
<p>Self-calibration display Err8</p>	<p>100g of lead was not added</p>	<p>Put on 100g of lead.</p>

7 . Pressure sensor structure and adjustment steps

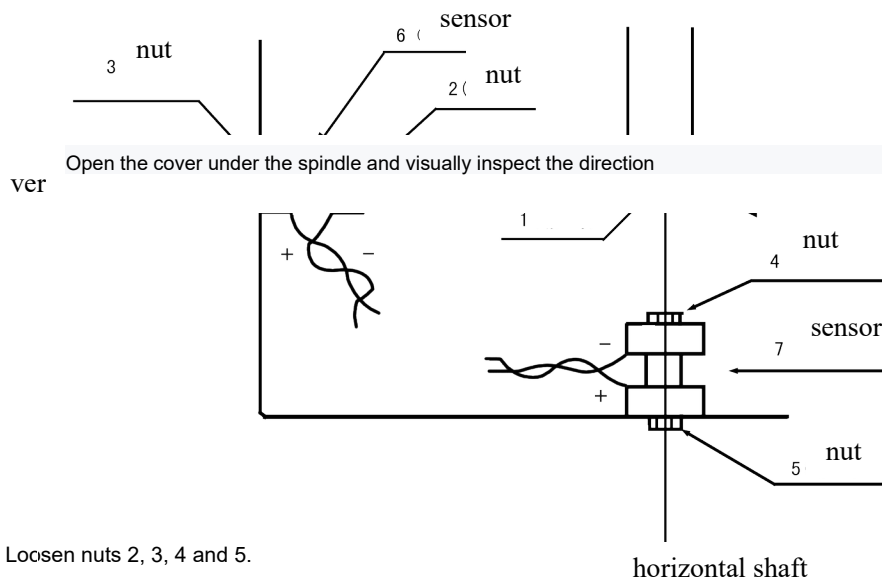

- (一) Loosen nuts 2, 3, 4 and 5.
- (二) dry sensor elements 6 and 7.
- (三) First tighten the nut 4 with a little bit of force, and then tighten the nut 5 firmly.
- (四) First tighten the nut 2 with a little bit of force, and then tighten the nut 3 firmly.

8 . Routine maintenance (non professional)

Please disconnect the power supply before carrying out maintenance operation.

8.1 Adjust belt tension

8.1.1 remove the hood.

8.1.2 Loosen the motor screw, move the motor until the belt is properly tensioned, and press down the belt with force, about 4mm lower ;

8.1.3 Tighten the motor screws and cover the hood.

8.2 Replace the fuse

Both fuses are installed on the power panel and can be removed from the fuse holder. Once damaged, they can be replaced with the same specifications of fuse.

Foreintrade S.A
Janówek, ul. Modrzewiowa 54
05-555 Tarczyn
NIP: 521-36-70-752; Regon: 147383292

A handwritten signature in blue ink, appearing to be 'M. J.', is written over the company name and partially over the address information.

DECLARATION OF CONFORMITY

According to ISO/IEC Guide 22 and EN 45014

Manufacturer: Foreintrade S.A

Manufacturer's address: Janówek, ul. Modrzewiowa 54 05-555 Tarczyn

WE DECLARE THAT THE PRODUCT IS COMPLIANT WITH EUROPEAN STANDARDS

Product name: Wheel balancer(marked with the Kraft&Dele trademark)

Model (trade designations): KD5842

Declaration:

The product to which this declaration refers meets the requirements of EC Directives:

1. 2006/42/EC Machinery Directive

According to standards:

EN ISO 12100:2010; EN 60204-1:2018

Person responsible for maintaining technical documentation: Ma Dong Hui, Janówek, ul. Modrzewiowa 54 05-555 Tarczyn

Ma Dong Hui, Tarczyn, 01.01.2025

Foreintrade S.A
Janówek, ul. Modrzewiowa 54
05-555 Tarczyn
NIP: 521-36-70-752; Regon: 147383292

