

KD5816

Instructions and Maintenance User Manual

KD5816

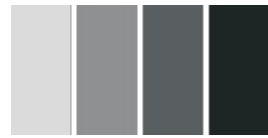

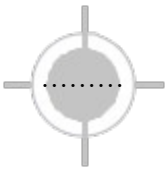

This instruction manual has been prepared especially for you. Your new lift is the product of over 15 years of continuous research, testing and development; it is the most technically advanced lift on the market today.

READ THIS ENTIRE MANUAL BEFORE INSTALLATION & OPERATION BEGINS

PRODUCT WARRANTY

What is not covered under this warranty:

- a. Any failure that results from Purchaser's abuse, neglect or failure to operate, maintain or service product in accordance with instructions provided in the owner's manual(s) supplied.
- b. Any damage caused by overloading lift beyond rated capacity.
- c. Items or service normally required to maintain the product, i.e. lubricants, oil, etc.
- d. Items considered general wear parts such as rubber pads, lifting cables, etc. unless wear or failure is a direct result of manufacturer defect due to material and/or workmanship.
- e. Any component damaged in shipment or any failure caused by installing or operating lift under conditions not in accordance with installation and operation guidelines or damaged by contact with tools or surroundings.
- f. Motor or pump failure caused by rain, excessive humidity, corrosive environments or other contaminants.
- g. Rusted components due to improper maintenance or corrosive environments.
- h. Cosmetic defects that do not interfere with product functionality.
- i. Damage due to incorrect voltage or improper wiring.
- j. Any incidental, indirect, or consequential loss, damage or expense that may result from any defect, failure or malfunction of Inc. product.
- k. All electrical components (excluding power unit) are guaranteed for one year against defects in workmanship and/or materials when the lift is installed and used according to specifications.

NOTE:

Every effort has been taken to ensure complete and accurate instructions have been included in this manual, however, possible product updates, revisions and or changes may have occurred since this printing. Our reserves the right to change specifications without incurring any obligation for equipment previously or subsequently sold. Not responsible for typographical errors



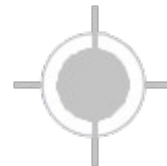

IMPORTANT NOTICE

Do not attempt to install this lift if you have never been trained on basic automotive lift installation procedures. Never attempt to lift components without proper lifting tools such as forklift or cranes. Stay clear of any moving parts that can fall and cause injury. These instructions must be followed to insure proper installation and operation of your lift. Failure to comply with these instructions can result in serious bodily harm and void product warranty. Manufacturer will assume no liability for loss or damage of any kind, expressed or implied resulting from improper installation or use of this product.

PLEASE READ ENTIRE MANUAL PRIOR TO INSTALLATION

- ◆ Follow all installation and operation instructions.
- ◆ Make sure installation conforms to all applicable Local, State, and Federal Codes, Rules, and Regulations; such as State and Federal OSHA Regulations and Electrical Codes.
- ◆ Carefully check the lift for correct initial function.
- ◆ Read and follow the safety instructions. Keep them readily available for machine operators.
- ◆ Make certain all operators are properly trained, know how to safely and correctly operate the unit, and are properly supervised.
- ◆ Allow unit operation only with all parts in place and operating safely.
- ◆ Carefully inspect the unit on a regular basis and perform all maintenance as required.
- ◆ Service and maintain the unit only with authorized or approved replacement parts.
- ◆ Keep all instructions permanently with the unit and all decals on the unit clean and visible.

DEFINITIONS OF HAZARD LEVELS

Identify the hazard levels used in this manual with the following definitions and signal words:

Watch for this symbol: It Means: Immediate hazards which will result in severe personal injury or death.

Watch for this symbol: It Means: Hazards or unsafe practices which could result in severe personal injury or death.

Watch for this symbol. It Means: Hazards or unsafe practices which may result in minor personal injury, product or property damage.

BEFORE YOU BEGIN

Receiving:The shipment should be thoroughly inspected as soon as it is received. The signed bill of lading is acknowledgement by the carrier of receipt in good condition of shipment covered by your invoice. If any of the goods called for on this bill of lading are shorted or damaged, do not accept them until the carrier makes a notation on the freight bill of the shorted or damaged goods. Do this for your own protection.

NOTIFY THE CARRIER AT ONCE if any hidden loss or damage is discovered after receipt and request the carrier to make an inspection. If the carrier will not do so, prepare a signed statement to the effect that you have notified the carrier (on a specific date) and that the carrier has failed to comply with your request.

IT IS DIFFICULT TO COLLECT FOR LOSS OR DAMAGE AFTER YOU HAVE GIVEN THE CARRIER A CLEAR RECEIPT.

File your claim with the carrier promptly. Support your claim with copies of the bill of lading, freight bill, invoice, and photographs, if available. Our willingness to assist in helping you process your claim does not make responsible for collection of claims or replacement of lost or damaged materials

OWNER'S RESPONSIBILITY



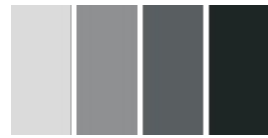
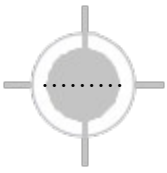

CONTENTS

Important notice.....	2
Important hints.....	4—6
check the parts according.....	7—8
machine parameters.....	9—10
tools required.....	11
specifications of concrete.....	12
select the location and layout of the installation.....	13
installation.....	14-22
important power unit installation notes.....	23
test run.....	24-25
optional and standard accessories.....	26
operation instructions.....	27
lift operation safety (cont'd).....	28-32
wire rope inspection and maintenance.....	33
safe lift operation.....	34-35
troubleshooting guide	36-38
drawing details	39-46



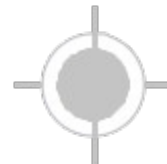

INSTALLER / OPERATOR PLEASE

READ AND FULLY UNDERSTAND. BY PROCEEDING, YOU AGREE TO THE

THIS SYMBOL POINTS OUT IMPORTANT SAFETY INSTRUCTIONS WHICH IF NOT FOLLOWED COULD ENDANGER THE PERSONAL SAFETY AND/OR PROPERTY OR YOURSELF AND OTHERS AND CAN CAUSE PERSONAL INJURY OR DEATH.

◆ I have visually inspected the site where the lift is to be installed and verified the concrete to be in good condition and free of cracks or other defects. I understand that installing a lift on cracked or defective concrete could cause lift failure resulting in personal injury or death..

◆ I understand that a level floor is required for proper installation and level lifting.

◆ I understand that I am responsible if my floor is of questionable slope and that I will be responsible for all charges related to pouring a new level concrete slab if required and any charges.

◆ I understand that the lifts are supplied with concrete fasteners meeting the criteria of the American National Standard "Automotive Lifts - Safety Requirements for Construction, Testing, and Validation" ANSI/ALI ALCTV- 2011, and that I will be responsible for all charges related to any special regional structural and/or seismic anchor- ing requirements specified by any other agencies and/or codes such as the Uniform Building Code (UBC) and/or International Building Code (IBC).

◆ I will assume full responsibility for the concrete floor and condition thereof, now or later, where the above equipment model(s) are to be installed. Failure to follow danger, warning, and caution instructions may lead to serious personal injury or death to operator or bystander or damage to property.

◆ I understand that lifts are designed to be installed in indoor locations only. Failure to follow installation instructions may lead to serious personal injury or death to operator or bystander or damage to property or lift.

Failure to follow danger, warning, and caution instructions may lead to serious personal injury or death to operator or bystander or damage to property.

Please read entire manual prior to installation. Do not operate this machine until you read and understand all the dangers, warnings and cautions in this manual.

INSTALLER / OPERATOR PROTECTIVE EQUIPMENT

Personal protective equipment helps make installation and operation safer, however, it does not take the place of safe operating practices. Always wear durable work clothing during any installation and/or service activity. Shop aprons or shop coats may also be worn, however, loose fitting clothing should be avoided. Tight fitting leather gloves are recommended to protect technician hands when handling parts. Sturdy leather work shoes with steel toes and oil resistant soles should be used by all service personnel to help prevent injury during typical installation and operation activities.

Eye protection is essential during installation and operation activities. Safety glasses with side shields, goggles, or face shields are acceptable. Back belts provide support during lifting activities and are also helpful in providing worker protection. Consideration should also be given to the use of hearing protection if service activity is performed in an enclosed area or if noise levels are high.



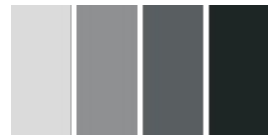
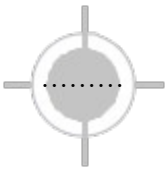

INTRODUCTION

1. Carefully remove the crating and packing materials. **CAUTION!** Be careful when cutting steelbanding material as items may become loose and fall causing personal harm or injury.

2. Check the voltage, phase and proper amperage requirements for the motor shown on the motor plate. Wiring should be performed by a certified electrician only

IMPORTANT SAFETY INSTRUCTIONS

Read these safety instructions entirely

IMPORTANT NOTICE

Do not attempt to install this lift if you have never been trained on basic automotive lift installation procedures. Never attempt to lift components without proper lifting tools such as forklift or cranes. Stay clear of any moving parts that can fall and cause injury.

1. Read and understand all instructions and all safety warnings before operating lift.
2. Care must be taken as burns can occur from touching hot parts.
3. Do not operate equipment with a damaged cord or if the equipment has been dropped or damaged until it has been examined by a qualified service person.
4. Do not let a cord hang over the edge of the table, bench, or counter or come in contact with hot manifolds or moving fan blades.
5. If an extension cord is necessary, a cord with a current rating equal to or more than that of the equipment should be used. Cords rated for less current than the equipment may overheat. Care should be taken to arrange the cord so that it will not be tripped over or pulled.
6. Always unplug equipment from electrical outlet when not in use. Never use the cord to pull the plug from the outlet. Grasp plug and pull to disconnect.
7. Let equipment cool completely before putting away. Loop cord loosely around equipment when storing.
8. To reduce the risk of fire, do not operate equipment in the vicinity of open containers of flammable liquids (gasoline).
9. Adequate ventilation should be provided when working on operating internal combustion engines.
10. Keep hair, loose clothing, fingers, and all parts of body away from moving parts. Keep feet clear of lift when lowering. Avoid pinch points.
11. **DANGER!** To reduce the risk of electric shock, do not use on wet surfaces or expose to rain. The power unit used on this lift contains high voltage. Disconnect power at the receptacle or at the circuit breaker switch before performing any electrical repairs. Secure plug so that it cannot be accidentally plugged in during service, or mark circuit breaker switch so that it cannot be accidentally switched on during service.



2. Use only as described in this manual. Use only manufacturer's recommended attachments.
13. **ALWAYS WEAR SAFETY GLASSES.** Everyday eyeglasses only have impact resistant lenses, they are not safety glasses.
14. Consider work environment. Keep work area clean. Cluttered work areas invite injuries. Keep areas well lit.
15. Guard against electric shock. This lift must be grounded while in use to protect operator from electric shock. Never connect the green power cord wire to a live terminal. This is for ground only.
16. Only trained operators should operate this lift. All non-trained personnel should be kept away from the work area. Never let non-trained personnel come in contact with, or operate lift.
17. **DO NOT** override self-closing lift controls.
18. Clear area if vehicle is in danger of falling.
19. **ALWAYS** make sure the safeties are engaged before attempting to work on or near a vehicle.
21. **WARNING! RISK OF EXPLOSION.** This equipment has internal arcing or sparking parts which should not be exposed to flammable vapors. This machine should not be located in a recessed area or below floor level.
22. **MAINTAIN WITH CARE.** Keep lift clean for better and safer performance. Follow manual for proper lubrication and maintenance instructions. Keep control handles and/or buttons dry, clean and free from grease and oil.
23. Check for damaged parts. Check for alignment of moving parts, breakage of parts or any condition that may affect operation of lift. Do not use lift if any component is broken or damaged.
24. **NEVER** remove safety related components from the lift. Do not use lift if safety related components are missing or damaged.
23. **STAY ALERT.** Use common sense and watch what you are doing. Remember, **SAFETY FIRST.**



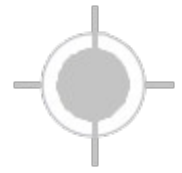

SAVE THESE INSTRUCTIONS

IMPORTANT NOTICE
 THESE INSTRUCTIONS MUST BE FOLLOWED TO INSURE PROPER INSTALLATION AND OPERATION OF YOUR LIFT. FAILURE TO COMPLY WITH THESE INSTRUCTIONS CAN RESULT IN SERIOUS BODILY HARM AND VOID PRODUCT WARRANTY. MANUFACTURER WILL ASSUME NO LIABILITY FOR LOSS OR DAMAGE OF ANY KIND, EXPRESSED OR IMPLIED, RESULTING FROM IMPROPER INSTALLATION OR USE OF THIS PRODUCT. PLEASE READ ENTIRE MANUAL PRIOR TO INSTALLATION

Selecting Site

Before installing your new lift, check the following.

1. **LIFT LOCATION:** Always use architect's plans when available. Check layout dimension against floor plan requirements making sure that adequate space is available.
2. **OVERHEAD OBSTRUCTIONS:** The area where the lift will be located should be free of overhead obstructions such as heaters, building supports, electrical lines etc.
3. **DEFECTIVE FLOOR:** Visually inspect the site where the lift is to be installed and check for cracked or defective concrete.



4. Lift is designed for **INDOOR INSTALLATION ONLY**. Outdoor use permitted only if covered and dry.
 Always follow warnings illustrated on equipment labels.

Floor Requirements



This lift must be installed on a solid level concrete floor with no more than 3°s of slope. Failure to do so

could cause personal injury or death. A level floor is suggested for proper use and installation and level lifting. If a floor is of questionable slope, consider a survey of the site and/or the possibility of pouring a new level concrete slab.

- ◆ DO NOT install or use this lift on any asphalt surface or any surface other than concrete.
- ◆ DO NOT install or use this lift on expansion seams or on cracked or defective concrete.
- ◆ DO NOT install or use this lift on a second / elevated floor without first consulting a building architect.



ALL MODELS MUST BE INSTALLED ON 3000 PSI
 CONCRETE ONLY CONFORMING TO THE
 MINIMUM REQUIREMENTS SHOWN ABOVE.
 NEW CONCRETE MUST BE ADEQUATELY CURED
 FOR A MINIMUM OF 28 DAYS.

When removing the lift from shipping angles, pay close attention as the posts can slide and can cause injury. Prior to removing the bolts make sure the posts are held securely by a fork lift or some other heavy lifting device.



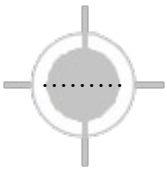

Check The Parts Before Assembly

1. Packaged lift and hydraulic power unit.

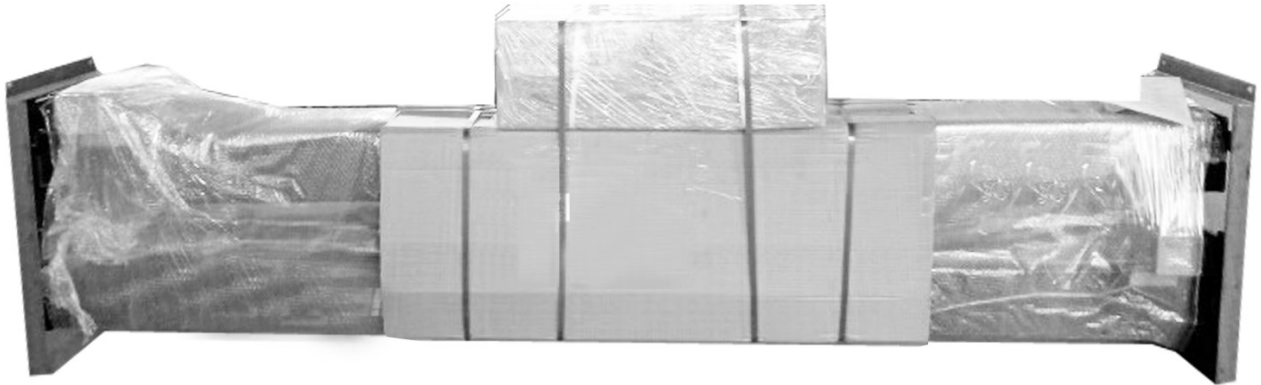

2. Move the lift aside with fork lift or hoist, and open the outer and inside the column, take out the parts box, check the parts.

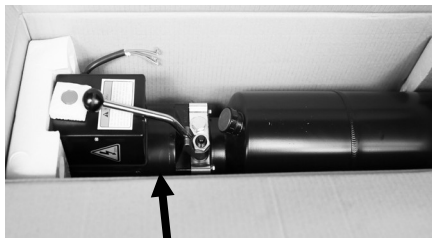

motor

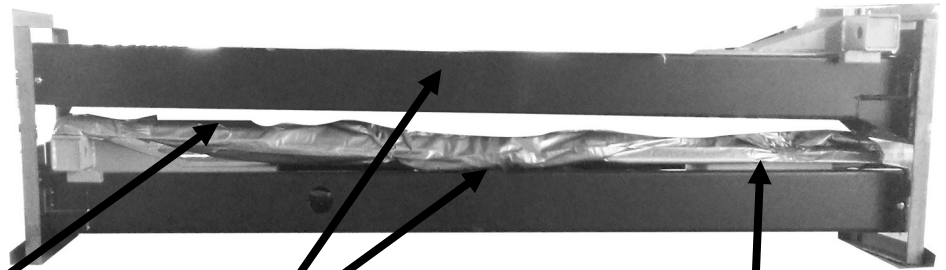

Floor cover

Off Side Post Assembly

Parts box

3. Loosen the screws of the upper package stand, take off the upper column and remove the package stand.

4. Move aside the parts and check the parts according to the shipment parts list.

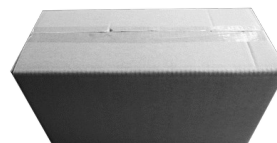
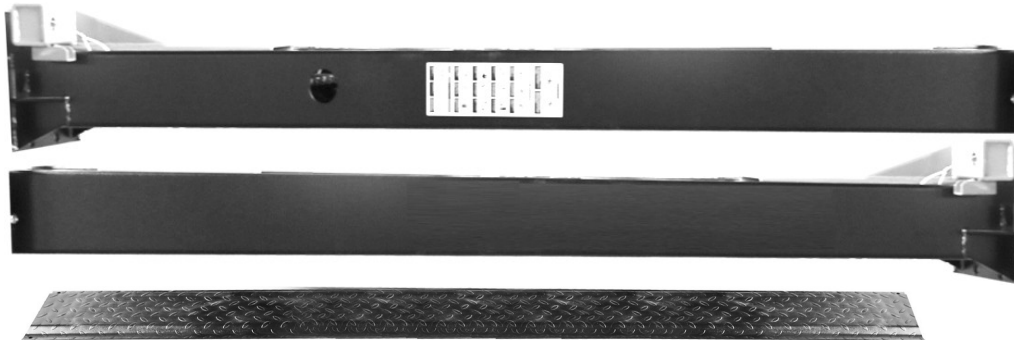

5. Parts in the parts box —outer arm machine

NOTE: view according to order type



6. Parts in the parts box —inner arm machine

NOTE: view according to order type



**NOTE: Accurate view by actual purchase order
(photo above for reference only)**

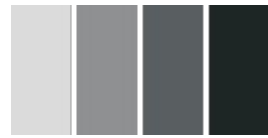
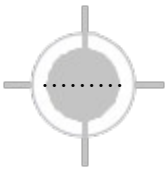

Machine parameters

Floorplate Chain-Drive Model Features

- Compact design, minimizes the lift wear parts and breakdown ratio
- Dual hydraulic cylinders, designed and made on ANSI standards.
- Self-lubricating UHMW polyethylene sliders and bronze bushings
- Double Point Release with dual safety design
- Standard super-symmetric arms can be used as symmetric or asymmetric

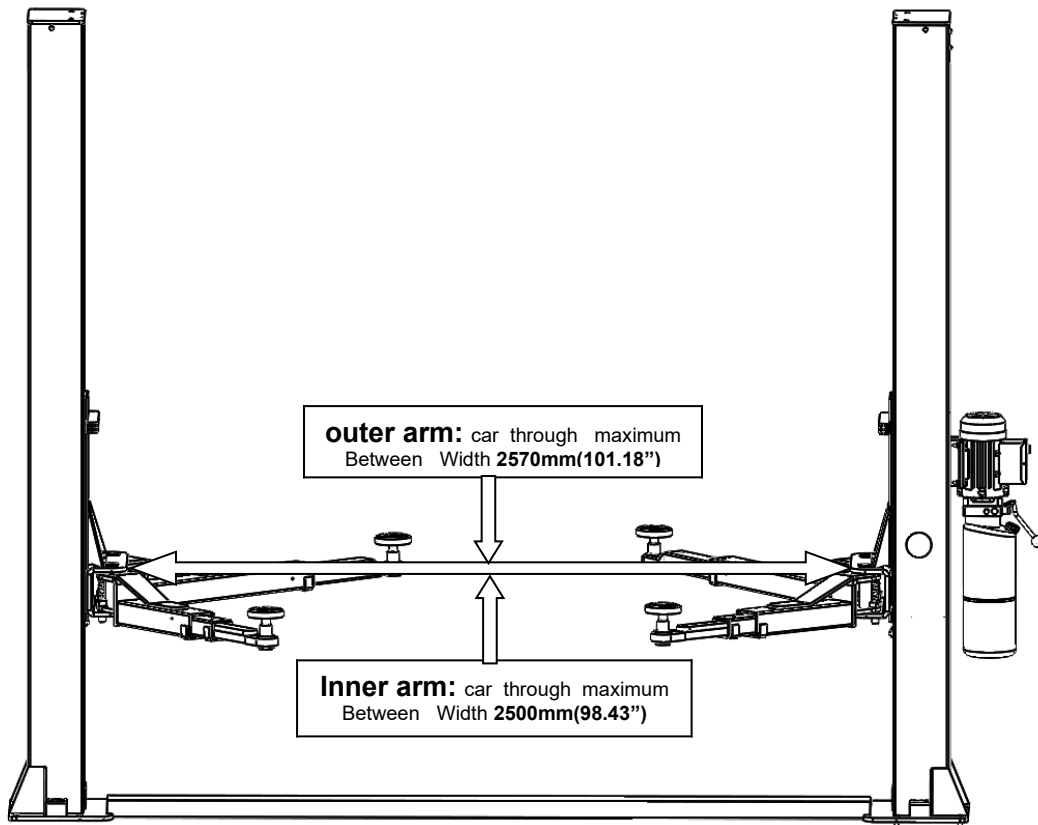

SPECIFICATIONS

Style	Lifting Capacity	Lifting Time	Lifting Height	Overall Width	Width Between Columns	Minimum Pad Height	Gross weight	Motor
Floor plate, Chain-driven	4000kg 9000lbs	45S	74.80" 1900mm	3470mm	110.24" 2800mm	110mm	570kg	2.2kW



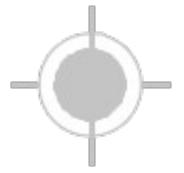

Arm Swing View (Accurate view by actual purchase order)

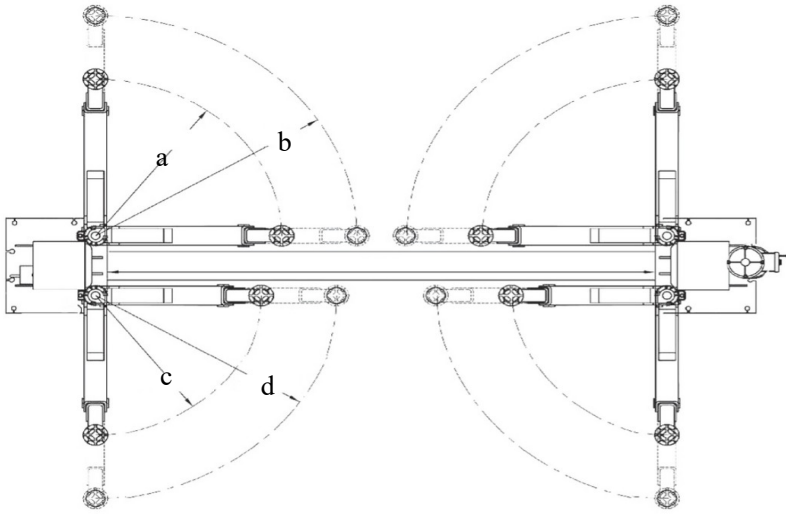

1. outer arm

2 long and 2 short- Lift arm

a-b : 29.92"—47.24"

(760-1200mm)

c-d : 27.95"—41.34"

(710-1050mm)

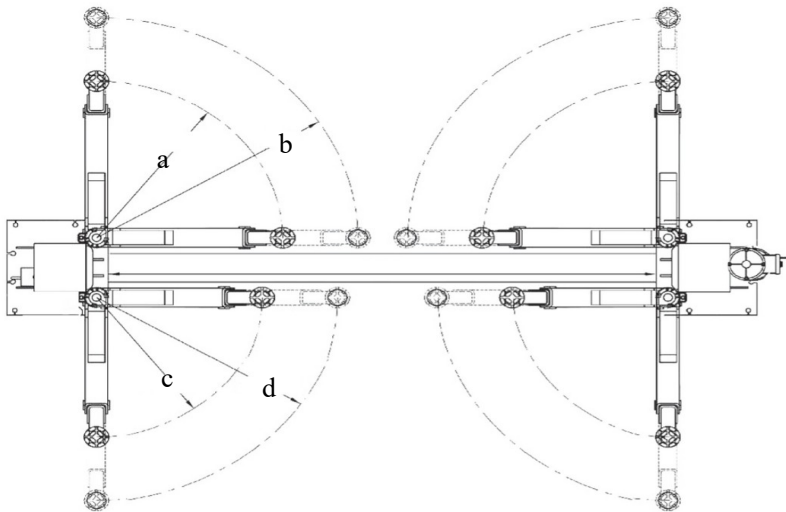

2. Inner arm

2 long and 2 short- Lift arm

a-b : 35.43"—55.12"

(900-1400mm)

c-d : 29.53"—45.28"

(750-1150mm)

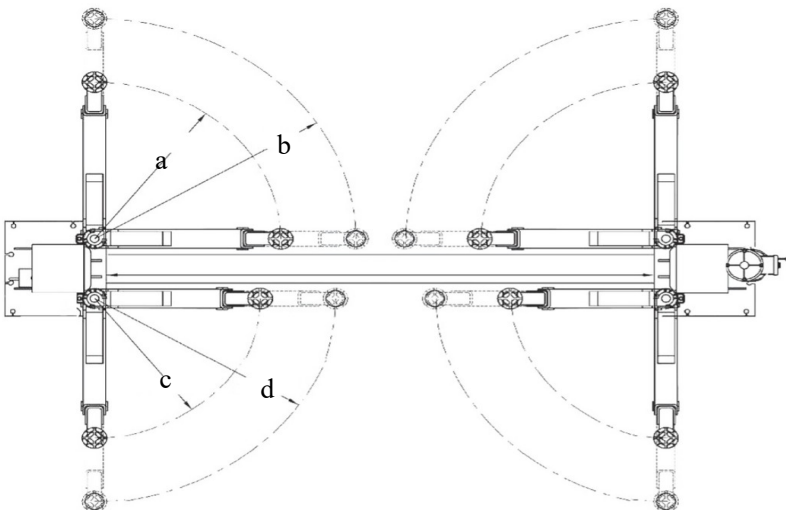

3. Inner arm

2 long and 3 short- Lift arm

a-b : 35.43"—57.09"

(900-1450mm)

c-d : 26.38"—44.88"

(670-1140mm)



Installation Requirements

Tools Required

Rotary Hammer Drill (3/4in /19mm)



Hammer



Level Bar



Crescent Wrench (12")



Ratchet Spanner With Socket (28#)

(6#)



Wrench set
(10#, 13#, 14#, 15#, 17#, 19#, 24#, 27#)



Carpenter's Chalk



Screw Drivers



Tape Measure (25ft)



Pliers



Allen Head Wrench



Vise Grips



Specifications Of Concrete

Concrete must be in compliance to the specifications below.

Failure To Do So May Result In Personal Injury or Property Damage.

1. Concrete must have a thickness of 6.3 inches minimum and without reinforcing steel bars, and must be completely cured before the lift installation.
2. Concrete must be in good condition and must have a test strength 3,000 psi (210kg/cm²) minimum.
3. ***Floors must be level and no cracks***

Power Supply

The capacity of power must be 3 HP minimum. The electrical wire must be a minimum of 10 gauge.

Select the location and layout of the installation

1. Location of Installation

Check the installation location (concrete, layout, space size etc.) so it is suitable for lift installation.

LIFT HEIGHT CLEARANCE NOTE: There must be 70" plus the height of typical vehicle MIN distance from top of lift to nearest obstruction

2. Use A Carpenter's Chalk Line To Establish Installation Layout Of Base Plate

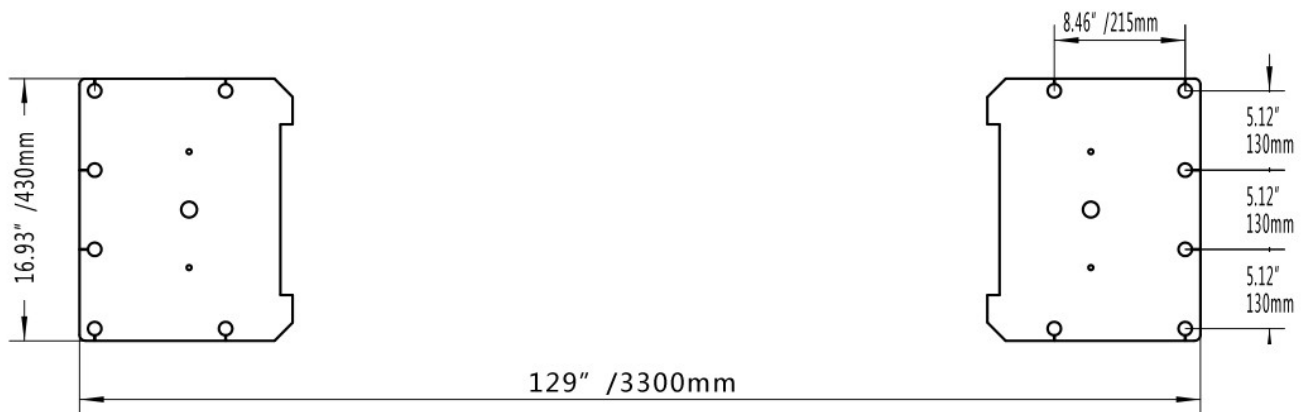

3. Using the base plate on the POWER SIDE post as a guide, drill each anchor hole in the concrete approximately 4.72" deep using a rotary hammer drill and 0.79" concrete drill-bit. To ensure full holding power, do not ream the hole or allow the drill to wobble.

4. After drilling, remove dust thoroughly from each hole making certain that the posts remain aligned with the chalk line

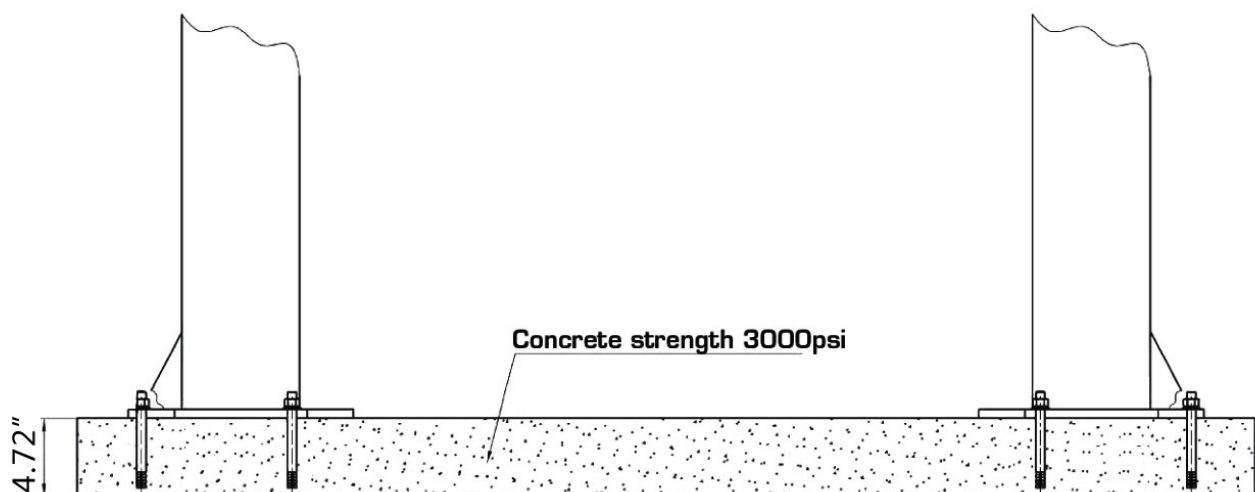

Position Power Side Columns

Lay down two posts on the installation site parallel, position the Power side post according to the actual installation environment.

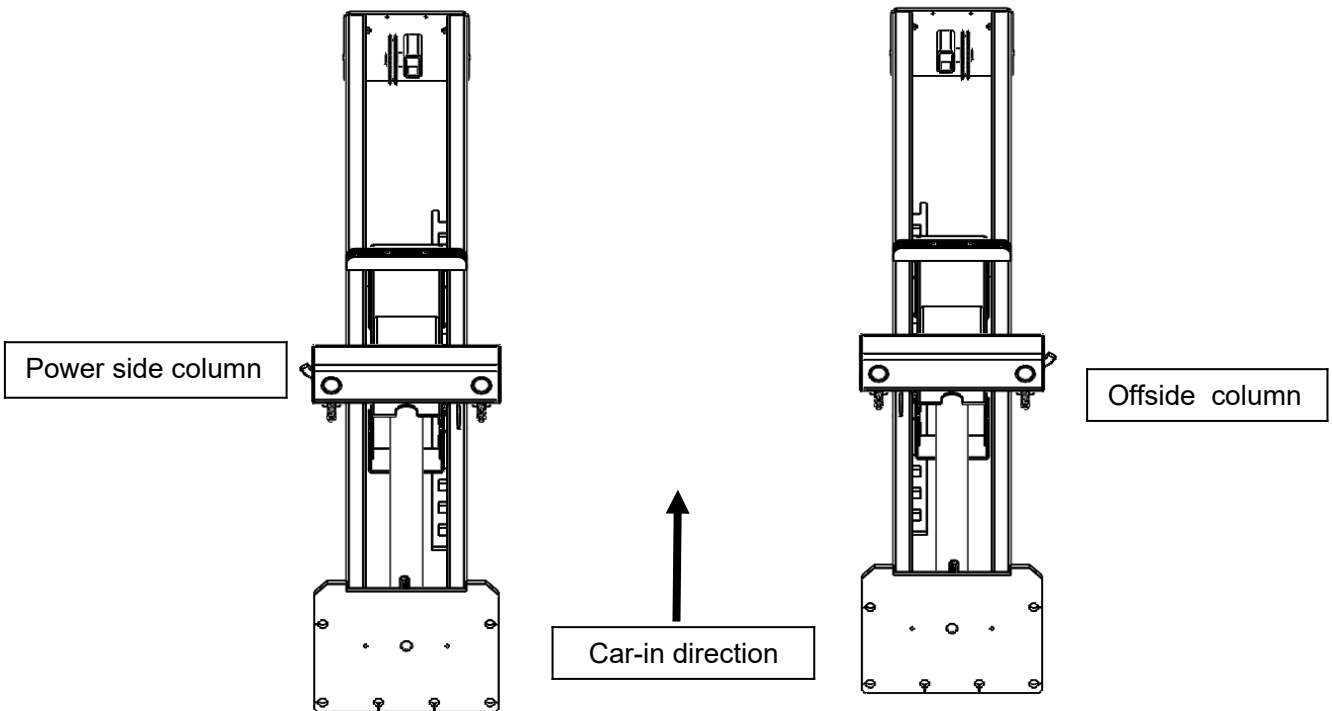

Position Columns

Check the columns are plumb with level bar, and adjusting with the shims if the columns are not vertical.

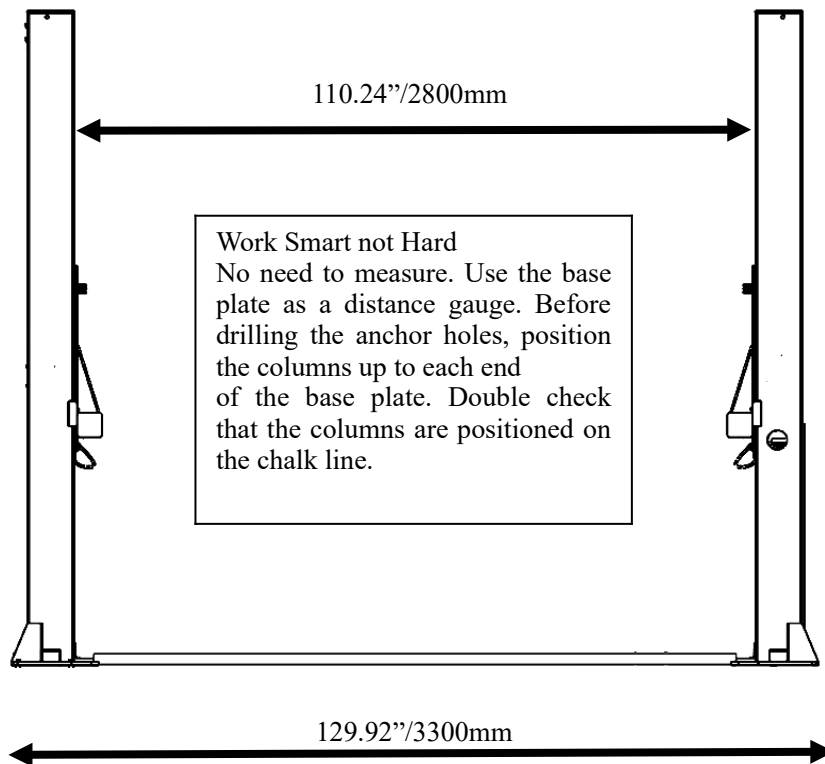

Fix Anchor Bolts

1. Prepare anchor bolts

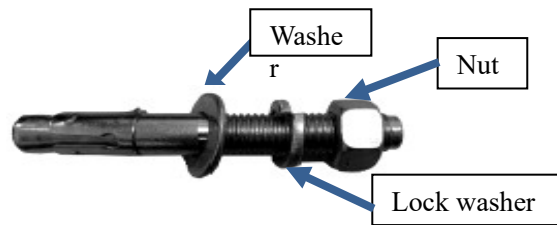

2. If shimming is required, insert the shims as necessary under the base plate so that when the anchor bolts are tightened, the posts will be plumb

3. Assemble the washers and nuts on the anchors then tap into each hole with a hammer until the washer rests against the base plate. If shimming is required be sure that enough threads are left exposed

4. With the foot guards, shims and anchor bolts in place, tighten by securing the nut to the base then turning 3-5 full turns clockwise. DO NOT use an impact wrench for this procedure

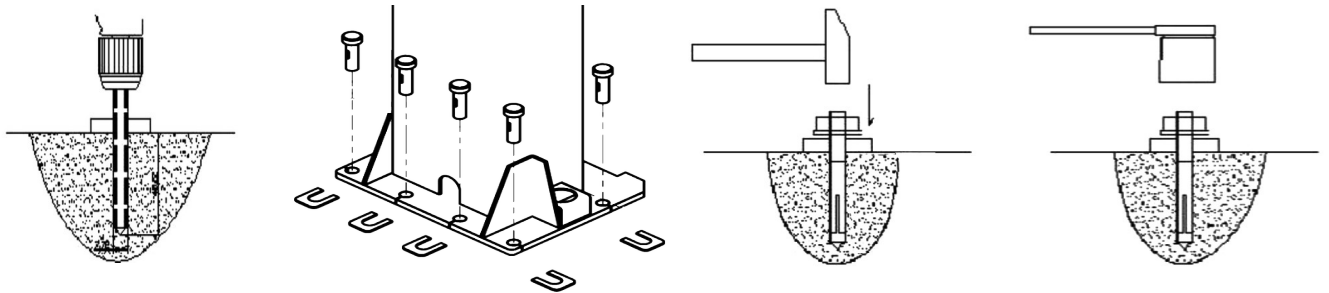

Install Cable

1. Lift the carriages up by hand and make them be locked at the same level, you can tell by the sound of locking "click"

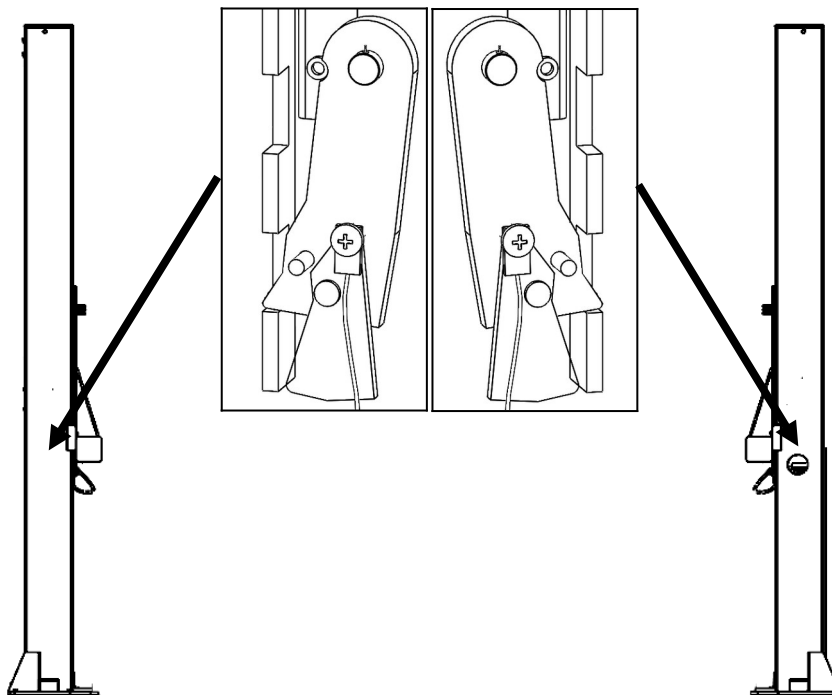

2. Install Balance cable

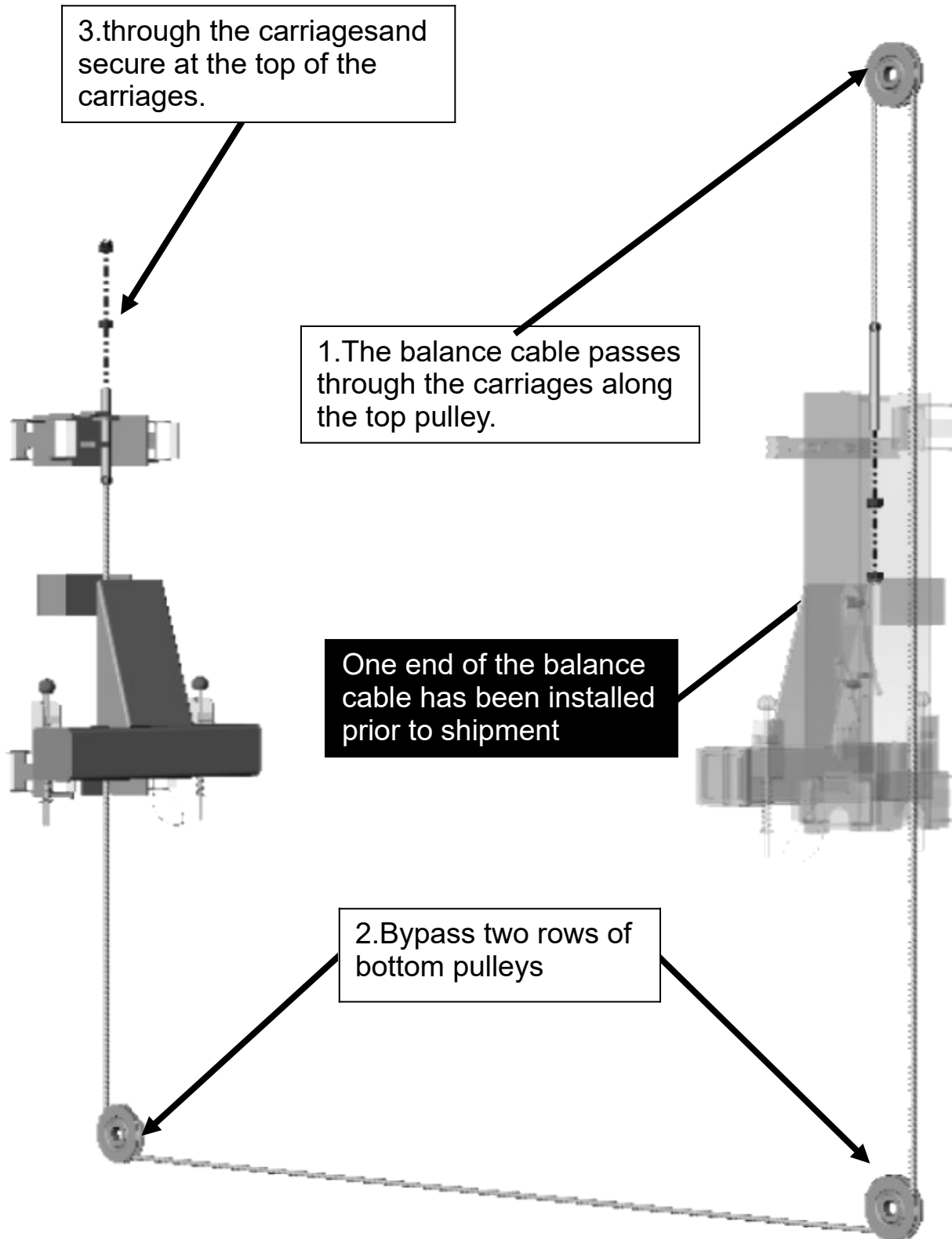

Install Hydraulic Power Unit And Oil Hose Assembly

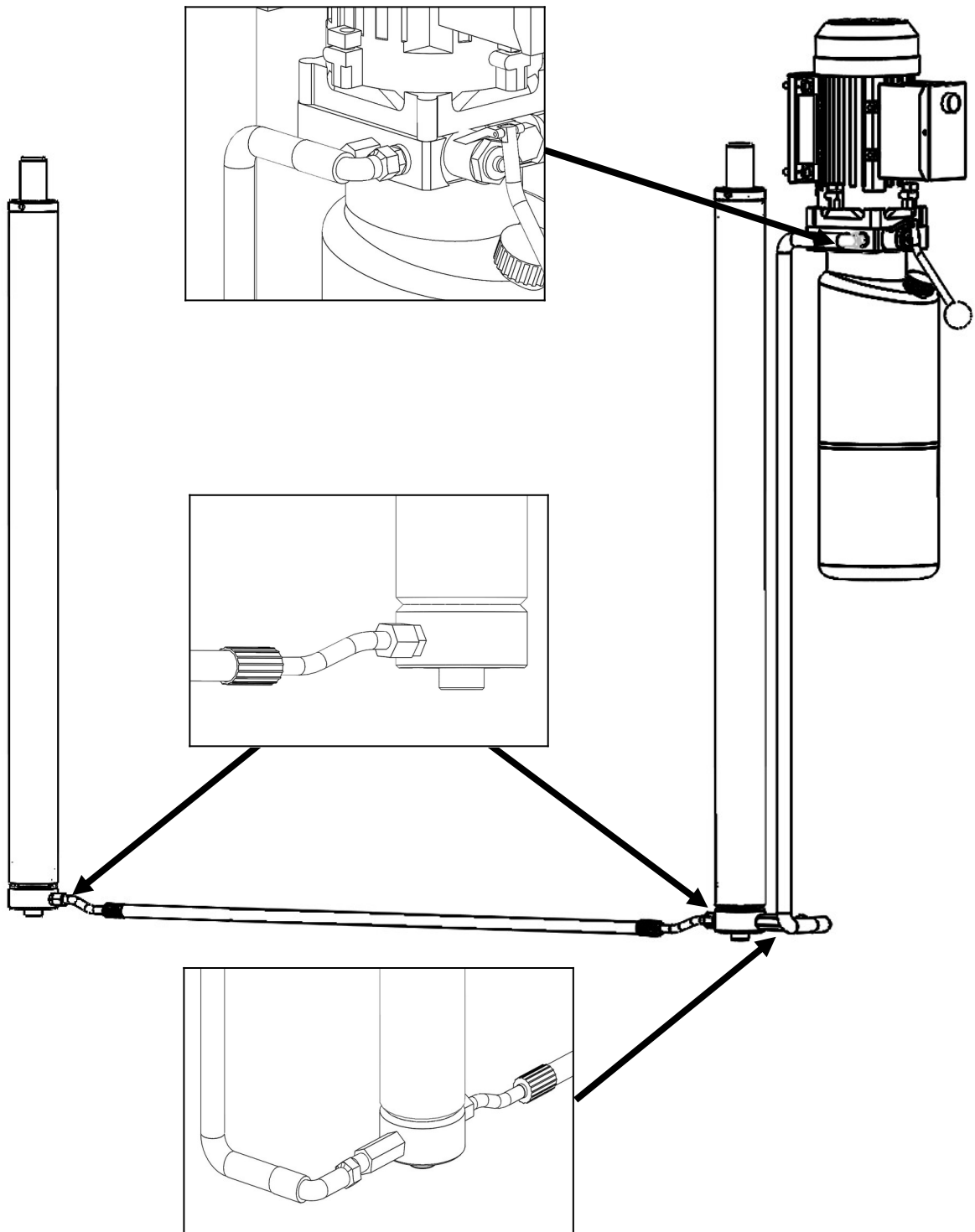

Use Teflon tape on all tapered(NPT) fittings. Do not use Teflon tape on the hydraulic hose (JIC) threads

Tighten all the hydraulic fittings, and fill the reservoir with approximately 2.6 gallons of hydraulic oil

Note :In consideration of hydraulic power unit's durability and keeping the equipment running in good condition, please use Hydraulic Oil 46#

Install limit switch

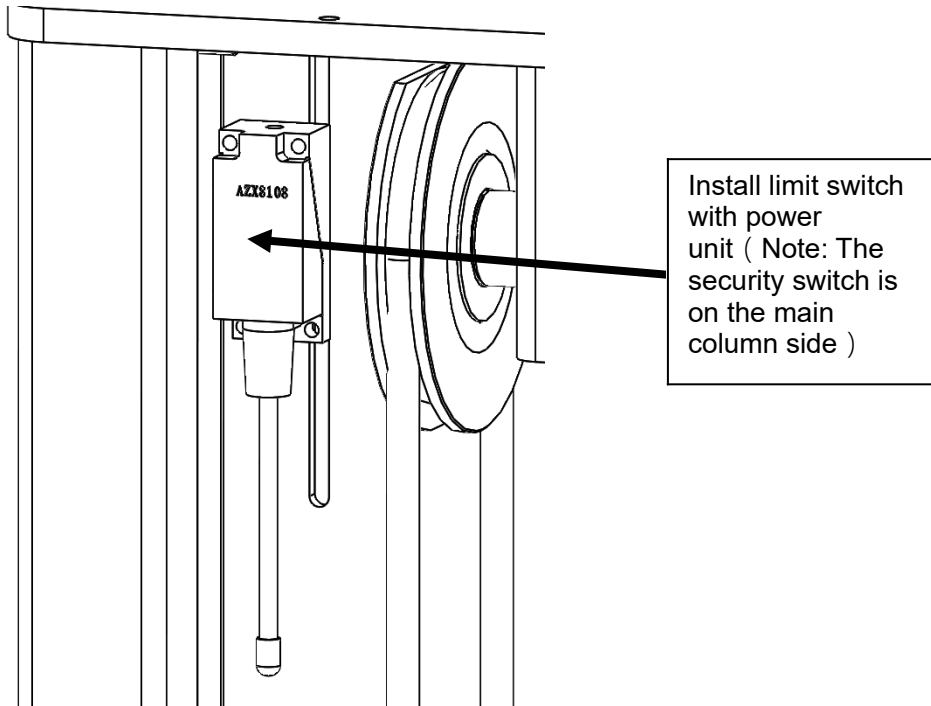

Assemble Floor Cover And Protective Rubber Sets

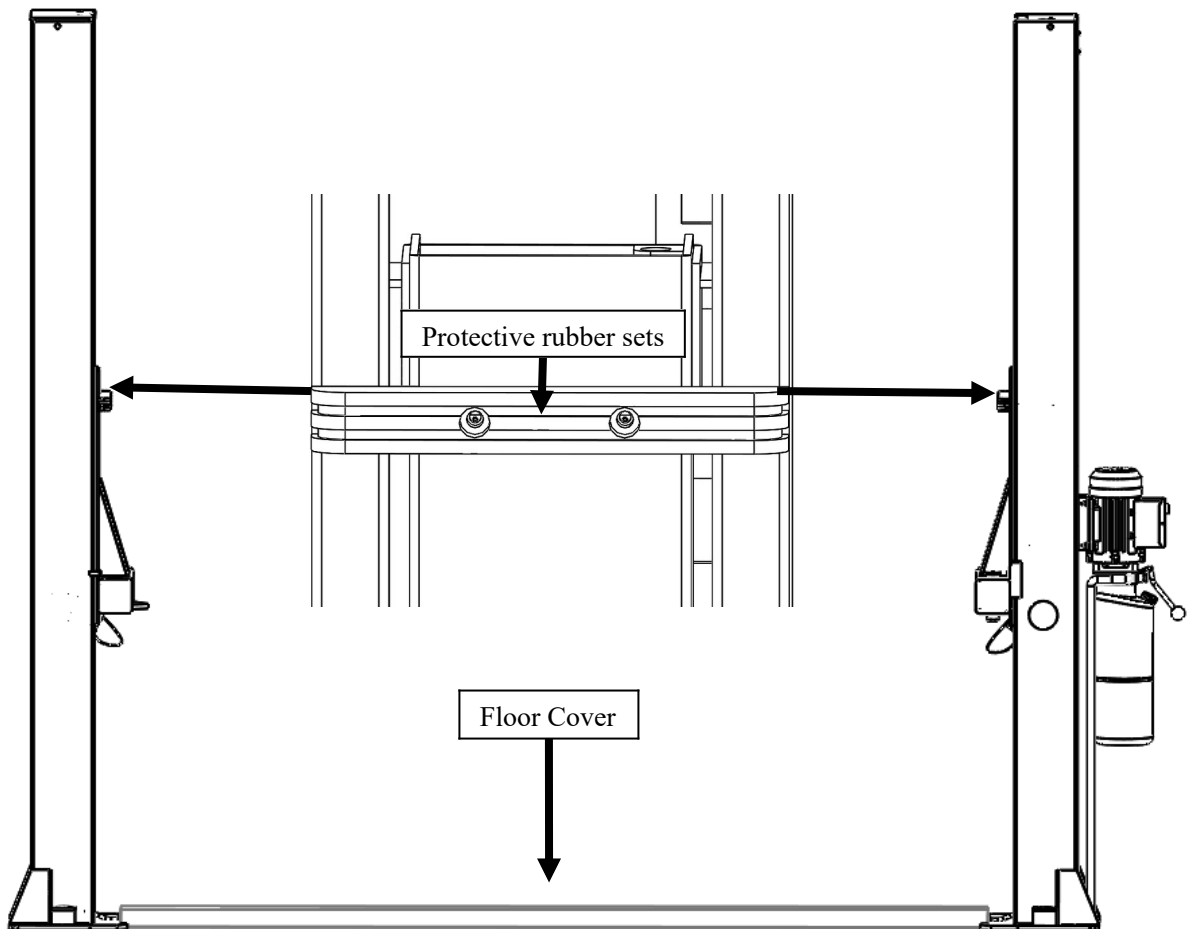

Install the Lift Arms (view according to order type)

Install Inner arm

1. Place the appropriate lift arm assembly in the lift heads.
2. Install the lift head pins into the lift head and through the holes in the arm assembly.
3. Each arm restraint gear can be oriented in a Left or Right configuration on the arms. Each arm and arm restraint gear must be positioned in the proper location in the lift head

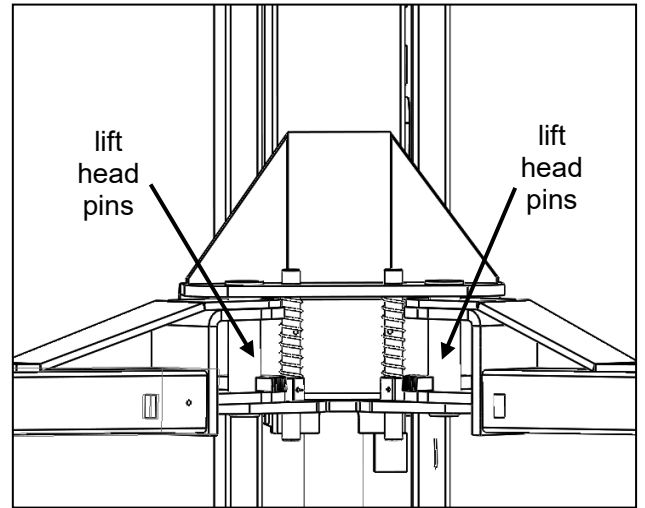
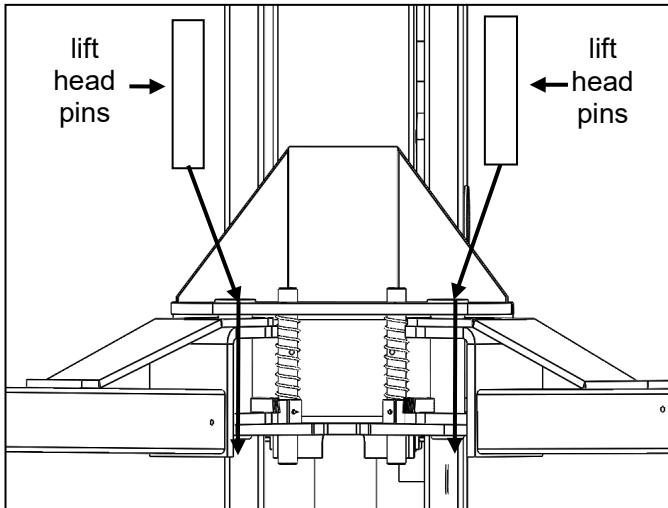

⚠ DANGER

THE ARM RESTRAINT GEARS MUST BE POSITIONED PROPERLY. CONFIRMATION OF PROPER GEAR ENGAGEMENT MUST BE MADE PRIOR TO THE OPERATION OF THE LIFT. PERIODIC INSPECTION IS REQUIRED. FAILURE TO INSPECT THE ARM RESTRAINT GEARS ON ALL FOUR ARMS PROPERLY CAN RESULT IN DAMAGE TO THE VEHICLE OR INJURY AND/OR DEATH.

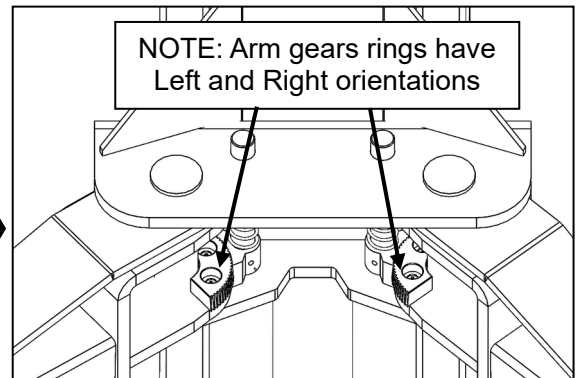

4. Place each Gear Ring against the Lift Head Pin and align the holes in the Gear Ring with the threaded holes in the Arm Ears. Ensure that the teeth on the Gear Ring mesh smoothly with the teeth on the gears of the Lift Head
5. Verify the operation of the arm restraints by pulling up on of the arm restraint pin. Pivot the arms back and forth and test the operation of the arm restraint pin in various positions
6. Ensure that the arms do not move when a force of approximately 100 pounds or less is applied laterally to the fully extended arms.

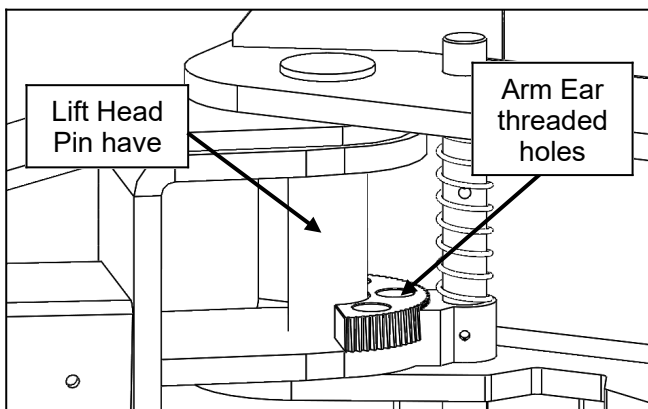

⚠ DANGER

NOTE: EACH ARM RESTRAINT ASSEMBLY MUST BE INSPECTED BEFORE EACH AND EVERY TIME THE LIFT IS OPERATED. DO NOT OPERATE THE LIFT IF ANY OF THE FOUR ARM RESTRAINT SYSTEMS ARE NOT FUNCTIONING PROPERLY.

Install Outer arm

1. Place the appropriate lift arm assembly in the lift heads.

2. Install the lift head pins in to the lift head and through the holes in the arm assembly.
3. Each arm restraint gear can be oriented in a Left or Right configuration on the arms. Each arm and arm restraint gear must be positioned in the proper location in the lift head
4. Install Arm Lock assembly in to the lift
5. Install Arm lock pins in to the lift

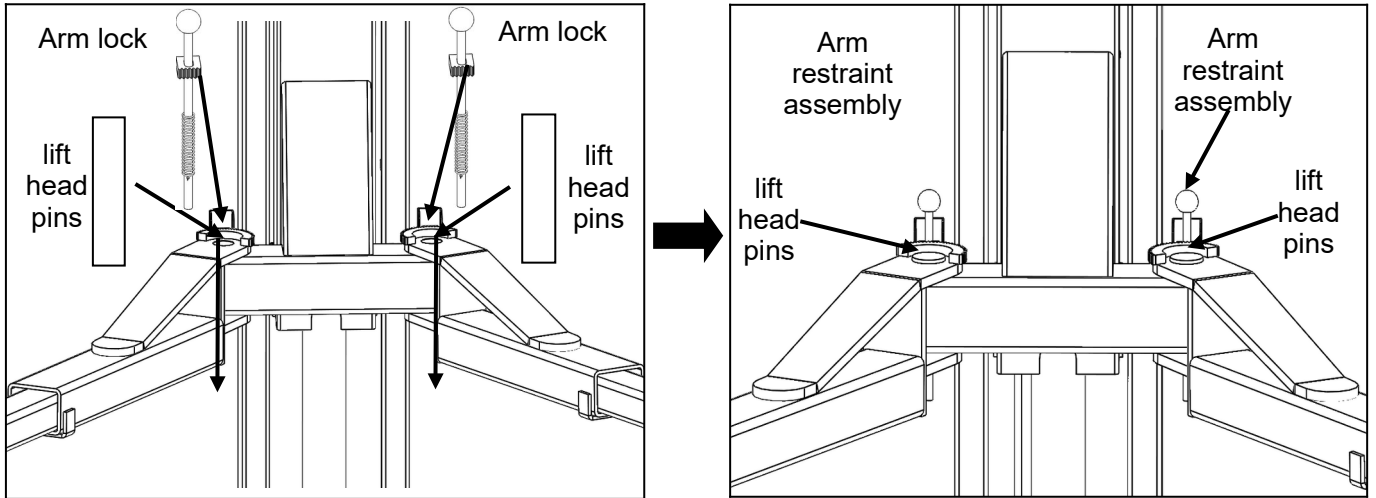

6 pulling up arm lock rod to ensure it is fully unlocked , adjust in this state. Adjust nut as shown

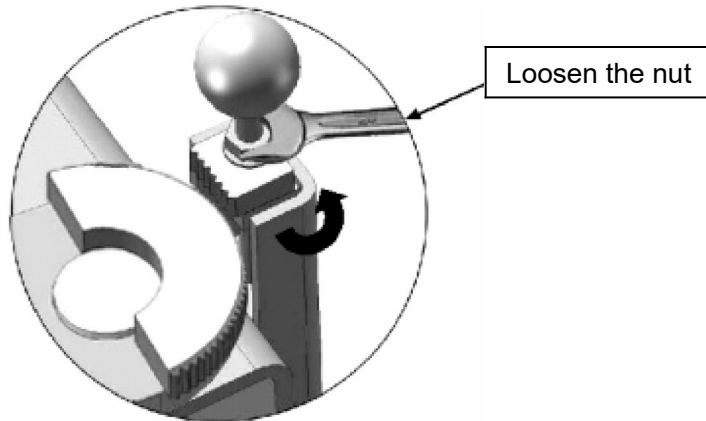

7. Adjust the arm lock. Follow the arrow direction.

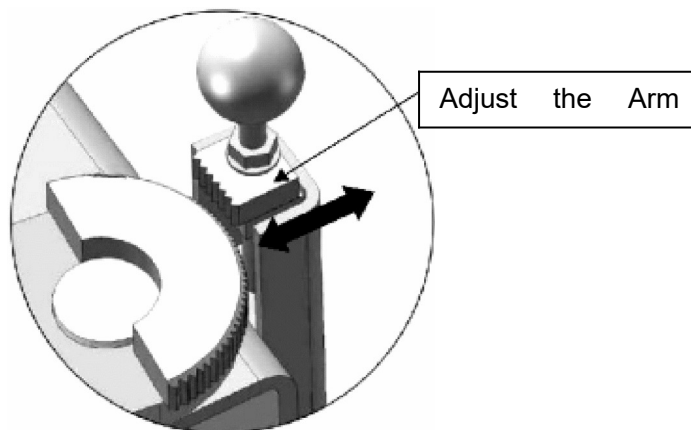

8. Adjust the teeth of arm lock assembly. Make it mesh with the gear on the lifting arm. Tighten the hex bolts on the arm lock assembly

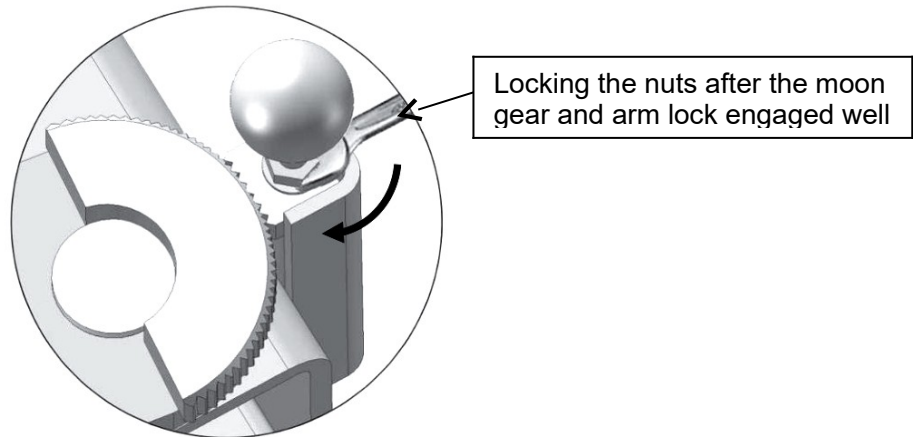

9. Verify the operation of the lift restraints by pulling up on of the arm restraint assembly. Pivot the arms back and forth and test the operation of the arm restraint pin in various positions
10.

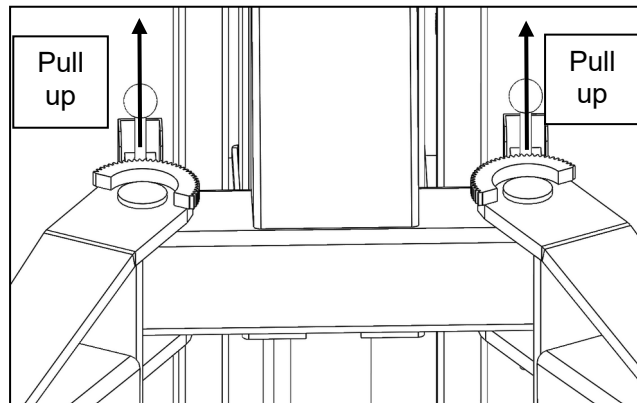

10. Ensure that the arms do not move when a force of approximately 100 pounds or less is applied laterally to the fully extended arms.

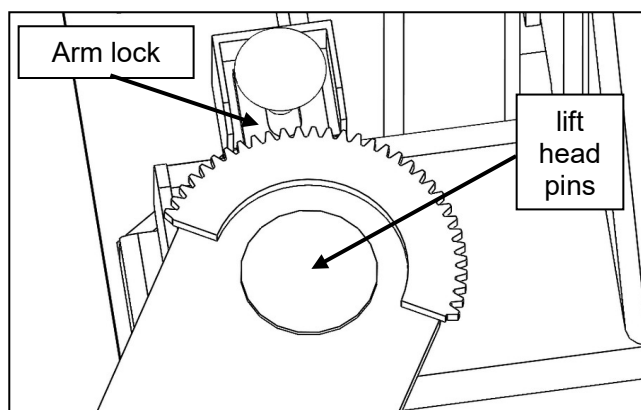

⚠ DANGER

NOTE: EACH ARM RESTRAINT ASSEMBLY MUST BE INSPECTED BEFORE EACH AND EVERY TIME THE LIFT IS OPERATED. DO NOT OPERATE THE LIFT IF ANY OF THE FOUR ARM RESTRAINT SYSTEMS ARE NOT FUNCTIONING PROPERLY.

CARRIAGE STOP BOLT INSTALLATION WARNING



YOU MUST RE-INSTALL TOP CARRIAGE-STOP BOLT (SHOWN BELOW). TIGHTEN CARRIAGE-STOP BOLT TO 2-3 FT.-LBS. OF TORQUE UPON FINAL INSTALLATION INSPECTION. THESE INSTRUCTIONS MUST BE FOLLOWED TO ENSURE PROPER INSTALLATION AND OPERATION OF YOUR LIFT. FAILURE TO COMPLY WITH THESE INSTRUCTIONS CAN RESULT IN SERIOUS BODILY INJURY AND/OR DEATH AND/OR VOID PRODUCT WARRANTY. MANUFACTURER WILL ASSUME NO LIABILITY FOR LOSS OR DAMAGE OF ANY KIND, EXPRESSED OR IMPLIED RESULTING FROM IMPROPER INSTALLATION OR USE OF THIS PRODUCT.

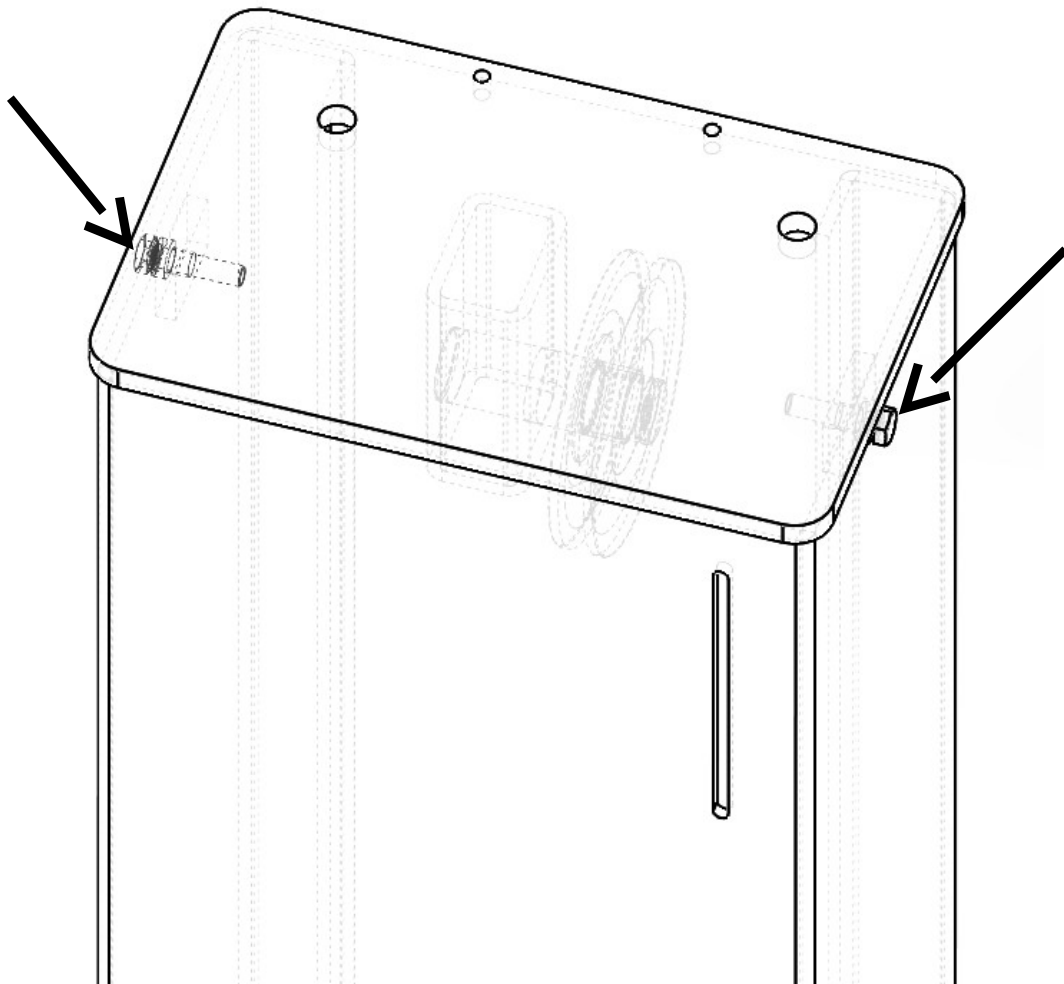

DO NOT PERFORM ANY MAINTENANCE OR INSTALLATION OF ANY COMPONENTS WITHOUT FIRST ENSURING THAT ELECTRICAL POWER HAS BEEN DISCONNECTED AT THE SOURCE OR PANEL AND CANNOT BE RE-ENERGIZED UNTIL ALL MAINTENANCE AND/OR INSTALLATION PROCEDURES ARE COMPLETED.

IMPORTANT POWER UNIT INSTALLATION NOTES



- DO NOT run power unit without oil. Damage to pump can occur.
- The power unit must be kept dry. Damage to power unit caused by water or other liquids such as detergents, acid etc., is not covered under warranty.
- Improper electrical connection can damage motor and will not be covered under warranty.
- Motor can not run on 50HZ without a physical change in the motor.
- Use a separate breaker for each power unit.
- Protect each circuit with time delay fuse or circuit breaker.
- For 208-230 volt, single phase, use a 25 amp fuse.
- For 208-230 volt, three phase, use a 20 amp fuse.
- For 380-440 volt, three phase, use a 15 amp fuse.

Installation and adjustment.

DO NOT attempt to raise vehicle until a thorough operation check has been completed.

ALL WIRING MUST BE PERFORMED BY A CERTIFIED ELECTRICIAN ONLY

Power Unit Connection

Have a certified electrician run the power supply to motor. Refer to the data plate found on the motor for proper power supply and wire size



RISK OF EXPLOSION

This equipment has internal arcing or parts that may spark and should not be exposed to flammable vapors. Motor should not be located in a recessed area or below floor level. NEVER expose motor to rain or other damp environments.

DAMAGE TO MOTOR CAUSED BY WATER IS NOT COVERED UNDER WARRANTY.

NOTE:

CAUTION NEVER OPERATE THE MOTOR ON LINE VOLTAGE LESS THAN 208V. MOTOR DAMAGE MAY OCCUR WHICH IS NOT COVERED UNDER WARRANTY. HAVE A CERTIFIED ELECTRICIAN RUN APPROPRIATE POWER SUPPLY TO MOTOR. SIZE WIRE FOR 25 AMP CIRCUIT. SEE MOTOR OPERATING DATA TABLE. USE SEPARATE CIRCUIT FOR EACH POWER UNIT. PROTECT EACH CIRCUIT WITH TIME DELAY FUSE OR CIRCUIT BREAKER. FOR SINGLE PHASE 208-230V, USE 25 AMP FUSE. THREE PHASE 208-240V, USE 25 AMP FUSE. FOR THREE PHASE 400V AND ABOVE, USE 15 AMP FUSE. ALL WIRING MUST COMPLY WITH NEC AND ALL LOCAL ELECTRICAL CODES.

Test Run

1. Adjust Synchronizing Cables

Carriages must be on first set of locks. Use vise grips to hold the cable fitting, meanwhile, use a wrench to tighten the cable nut. Make sure the two cables have the same tension so the carriages lift at the same time.

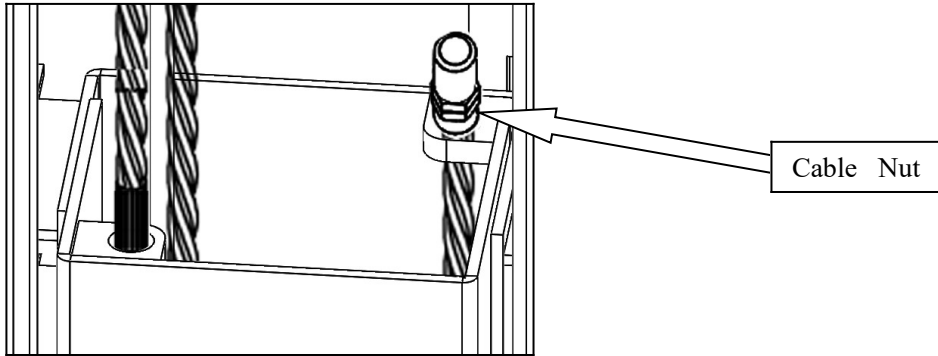

If the carriages do not synchronize when lifting, please read below

a. Press UP button to lift the carriages up to the position where the first safety lock of one carriage is higher than the safety lock on the column. Lower the lift until the lower of the two carriages makes contact with the safety lock on the column.

b. Loosen the safety lock cable. Release the safety lock on the side where the carriage is in the higher position. The other side of the safety lock should be engaged at this time. Then lower the lift, and the side with the carriage in the lower position will remain locked in the same place, and the other side (higher side) is unlocked. Continue to lower down the lift until the higher carriage is at the same level as the lower carriage.

c. Loosen the jam nut on the higher carriage synchronizing cable and tighten the tension nut until the synchronizing cable has the same tension as the other synchronizing cable. Tighten the jam nut and safety cable.

2. Adjust the lower speed (Only for ATLAS power unit)

You can adjust the lowering speed of the lift if needed. Loosen the locking nut on the Throttle Valve and turn the Throttle Valve clockwise to decrease the lowering speed or counterclockwise to increase the lowering speed. Do not forget to tighten the locking nut after the lowering speed adjustment has been done.

Note: This procedure must be done with a load on the lift.

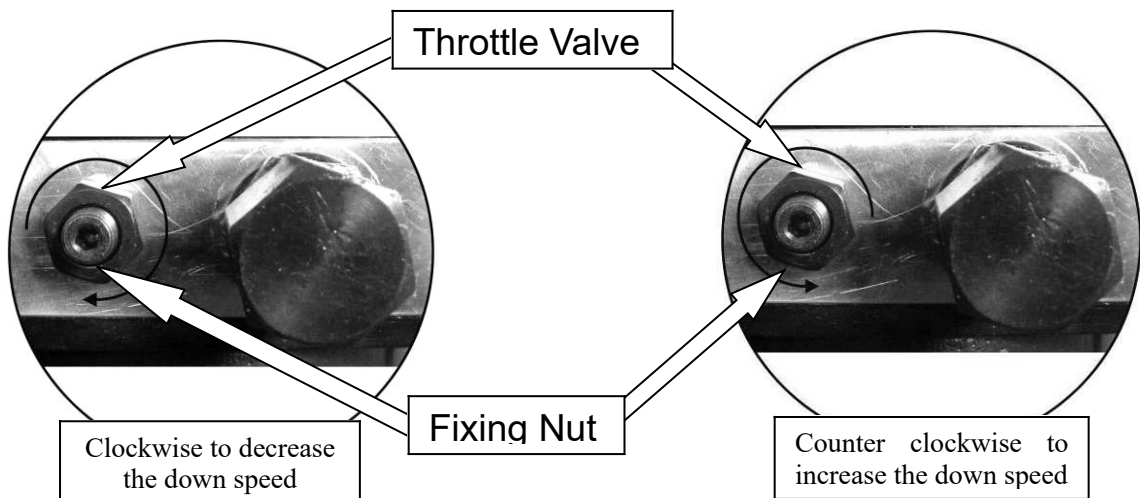

(Lift Start Up / Final Adjustments)



DURING THE START-UP PROCEDURE, OBSERVE ALL OPERATING COMPONENTS AND CHECK FOR PROPER INSTALLATION AND ADJUSTMENT. DO NOT ATTEMPT TO RAISE VEHICLE UNTIL A THOROUGH OPERATIONAL CHECK HAS BEEN COMPLETED.

1. Make sure the power unit reservoir is full with (2.6) gallons of 10-WT hydraulic oil or Dexron automatic transmission fluid.
2. Apply light axle grease to the inside of the posts where the slide blocks glide.
3. Test the power unit by pressing the push-button switch. If the motor sounds like it is operating properly, raise the lift and check all hose connections for leaks. If the motor gets hot or sounds peculiar, stop and check all electrical connections.
4. Before proceeding, double-check to make sure all cables are properly positioned within the grooves of ALL sheaves. Make sure all cable sheave retaining pins and/or clips are secure.
5. Continue to press the button to raise lift until the cables get taut and the lift starts to move.
6. KEEP HANDS AND FEET CLEAR. Remove hands and feet from any moving parts. Keep feet clear of lift when lowering. Avoid pinch points.
7. Check all MAIN SAFETY LOCKS to make sure they move freely
8. Cycle the lift up and down a few times to ensure that the safety locks are engaging uniformly and that the safety release mechanisms are functioning. Re-adjust if necessary.



POST-INSTALLATION CHECK-OFF

1. Columns properly shimmed and stable
2. Anchor Bolts tightened
3. Pivot / Sheave Pins properly attached
4. Electric power supply confirmed
5. Cables adjusted properly
6. Safety Locks functioning properly
7. Check for hydraulic leaks
8. Oil level
9. Lubrication of critical components
- 10 Check for overhead obstructions
11. All Screws, Bolts, and Pins securely fastened
12. Surrounding area clean
13. Operation, Maintenance and Safety Manual on site.
14. Perform an Operational Test with a typical vehicle

OPTIONAL AND STANDARD ACCESSORIES

✓ included standard

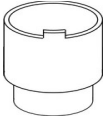
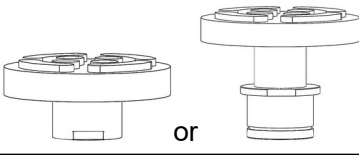
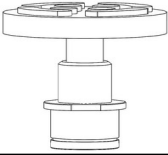
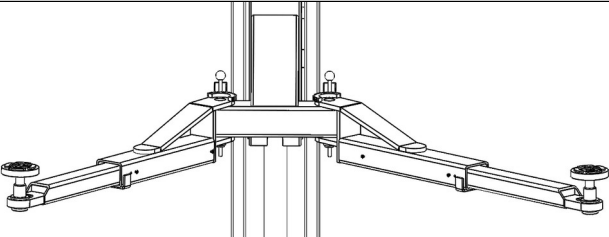
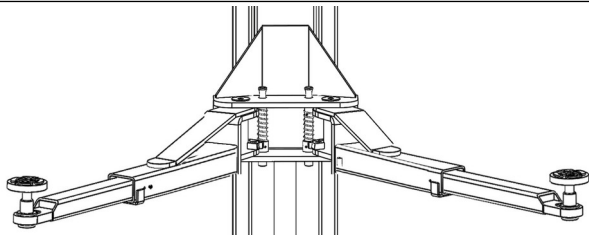
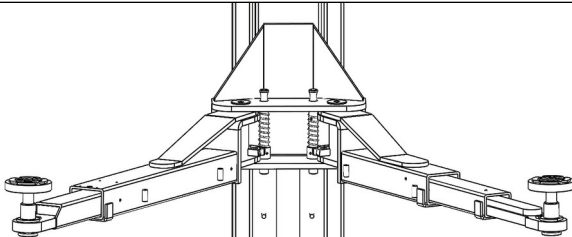
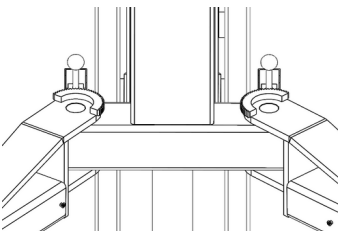
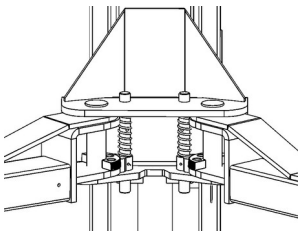
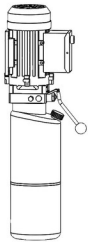
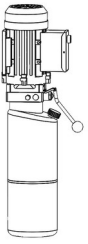
× not included/optional

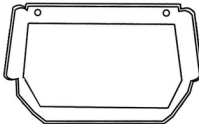
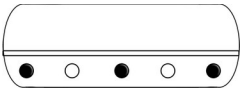
				
85mm Height Adaptor	40mm Height Adaptor	Direct-insert tray or Single Spiral tray	Double spiral tray	
✓	×	✓	×	
				
2 long + 2 short- Lift arm		2 long + 2 short- Lift arm		
✓		×		
				
2 long + 3 short- Lift arm	Outer arm	inner arm		
×	✓	×		
				
Iron motor Plastic oil tank Or Iron oil tank	Aluminum motor Iron oil tank Or Plastic oil tank	Aluminum motor Iron oil tank Or Plastic oil tank (only Electrolytic locks- optional)	Tool tray	curtain prevent dust (only Mechanical Dual-point Release -optional)
✓	×	×	×	×

(Operation Instructions)

OWNER/EMPLOYER RESPONSIBILITIES

- Shall ensure that lift operators are qualified and that they are trained in the safe use and operation of the lift using the manufacturer's operating instructions; ALI/SM01-1, ALI Lifting it Right safety manual; ALI/ST-90 ALI Safety Tips card; ANSI/ALI ALOIM-2000, American National Standard for Automotive Lifts Safety Requirements for Operation, Inspection and Maintenance; ALI/WL Series, ALI Uniform Warning Label Decals/Placards; and in the case of frame engaging lifts, ALI/LP-GUIDE, Vehicle Lifting Points/Quick Reference Guide for Frame Engaging Lifts.
- Shall establish procedures to periodically inspect the lift in accordance with the lift manufacturer's instructions or ANSI/ALI ALOIM-2000, American National Standard for Automotive Lifts-Safety Requirements for Operation, Inspection and Maintenance; and The Employer shall ensure that lift inspectors are qualified and that they are adequately trained in the inspection of the lift.
- Shall establish procedures to periodically maintain the lift in accordance with the lift manufacturer's instructions or ANSI/ALI ALOIM-2000, American National Standard for Automotive Lifts-Safety Requirements for Operation, Inspection and Maintenance; and The Employer shall ensure that lift maintenance personnel are qualified and that they are adequately trained in the maintenance of the lift.

LIFT OPERATION SAFETY

- DAILY inspect your lift. Never operate if it malfunctions or if it has broken or damaged parts. Use only qualified lift service personnel and genuine parts to make repairs.
- THOROUGHLY train all employees in use and care of lift, using manufacturer's instructions and "Lifting It Right" and "Safety Tips" supplied with the lift.
- NEVER allow unauthorized or untrained persons to position vehicle or operate lift.
- PROHIBIT unauthorized persons from being in shop area while lift is in use.
- DO NOT permit anyone on lift or inside vehicle when it is either being raised or lowered.
- ALWAYS keep area around lift free of tools, debris, grease and oil.
- NEVER overload lift. Capacity of lift is shown on

- Shall maintain the periodic inspection and maintenance records recommended by the manufacturer or ANSI/ALI ALOIM-2000, American National Standard for Automotive Lifts-Safety Requirements for Operation, Inspection and Maintenance.

- Shall display the lift manufacturer's operating instructions; ALI/SM 93-1, ALI Lifting It Right safety manual; ALI/ST-90 ALI Safety Tips card; ANSI/ALI AL- OIM-2000, American National Standard for Automotive Lifts-Safety Requirements for Operation, Inspection and Maintenance; and in the case of frame engaging lifts, ALI/LP-GUIDE, Vehicle Lifting Points/Quick Reference Guide for Frame Engaging Lifts; in a conspicuous location in the lift area convenient to the operator.



- Shall provide necessary lockout/tagout means for energy sources per ANSI Z244.1-1982 (R1993), Safety Requirements for the Lockout/Tagout of Energy Sources, before beginning any lift repairs.
- Shall not modify the lift in any manner without the prior written consent of the manufacturer.

nameplate affixed to the lift.

- DO NOT stand in front of the vehicle while it is being positioned in lift bay.
- DO NOT hit or run over lift arms or adapters. This could damage lift or vehicle. Before driving vehicle into lift bay, position arms and adapters to provide unobstructed entrance onto lift.

LIFT OPERATION SAFETY (CONT'D)



- ALWAYS load vehicle on lift carefully. Position the lift adapters to contact at the vehicle manufacturer's recommended lift points. Raise lift until adapters contact vehicle. Check adapters for secure contact with vehicle.

Raise lift to desired working height.

- DO NOT block open or override self-closing lift controls; they are designed to return to the "Off" or Neutral position when released.
- DO NOT remove or disable arm restraints.
- ALWAYS remain clear of lift when raising or lowering vehicles.
- ALWAYS use safety stands when removing or installing heavy components.
- DO NOT go under raised vehicle if safety locks are not engaged.



VISUALLY CONFIRM THAT ALL PRIMARY SAFETY LOCKS ARE ENGAGED BEFORE ENTERING WORK AREA. SUSPENSION COMPONENTS USED ON THIS LIFT ARE INTENDED TO RAISE AND LOWER LIFT ONLY AND ARE NOT MEANT TO BE LOAD HOLDING DEVICES. REMAIN CLEAR OF ELEVATED LIFT UNLESS VISUAL CONFIRMATION IS MADE THAT ALL PRIMARY SAFETY LOCKS ARE FULLY ENGAGED AND THE LIFT IS LOWERED ONTO THE SAFETY LOCKS, REFER TO INSTALLATION/ OPERATION MANUAL FOR PROPER SAFETY LOCK PROCEDURES AND/OR FURTHER INSTRUCTION.

- NEVER LEAVE LIFT IN ELEVATED CONDITION unless all Safety Locks are engaged.
- AVOID excessive rocking of vehicle while on lift.
- ALWAYS CLEAR AREA if vehicle is in danger of falling.



WHEN LOWERING THE LIFT PAY CAREFUL ATTENTION THAT ALL PERSONNEL AND OBJECTS ARE KEPT CLEAR. ALWAYS KEEP A VISUAL LINE OF SITE ON THE LIFT AT ALL TIMES. ALWAYS

MAKE SURE THAT ALL LOCKS ARE DISENGAGED. IF ONE OF THE LOCKS INADVERTENTLY LOCKS ON DESCENT THE LIFT AND/OR VEHICLE MAY DISRUPT CAUSING PERSONAL INJURY OR DEATH.

- ALWAYS REMOVE tool trays, stands, etc. Before lowering lift.
 - ALWAYS RELEASE safety locks before attempting to lower lift.
 - ALWAYS POSITION the lift arms and adapters to provide an unobstructed exit before removing vehicle from lift area.
- TO RAISE THE LIFT



TO AVOID PERSONAL INJURY AND/OR PROPERTY DAMAGE, PERMIT ONLY TRAINED PERSONNEL TO OPERATE LIFT. AFTER REVIEWING THESE INSTRUCTIONS, PRACTICE USING LIFT CONTROLS BY RUNNING THE LIFT THROUGH A FEW UNLOADED CYCLES BEFORE LOADING VEHICLE ON LIFT. ALWAYS LIFT THE VEHICLE USING ALL FOUR ADAPTERS. NEVER RAISE JUST ONE END, ONE CORNER, OR ONE SIDE OF VEHICLE

1. Before Loading: Lift must be fully lowered and service bay clear of all personnel before the vehicle is brought on lift with the swing arms set to the full drive-thru position.
2. Loading: Swing arms under vehicle and position adapters at vehicle manufacturer's recommended lift points. Use height extenders or optional frame-cradle adapters when necessary to ensure good contact.
3. Some vehicles may have the manufacturer's Service Garage Lift Point locations identified by triangle shape marks on the undercarriage (reference ANSI/SAE J2184- 1992). Also, there may be a label located on the right front door jamb area showing specific vehicle lift points.

LIFT OPERATION SAFETY (CONT'D)



MANY SPECIALTY OR MODIFIED VEHICLES CAN- NOT BE RAISED ON A TWO-POST FRAME ENGAG- ING LIFT. CONTACT VEHICLE MANUFACTURER FOR RAISING OR JACKING DETAILS

•Push the RAISE button or rotate the control switch on the power unit

NOTE:
ALLOW (2) SECONDS BETWEEN MOTOR STARTS.
FAILURE TO COMPLY MAY CAUSE MOTOR BURNOUT.

•Stop before making contact with vehicle. Check arm restraint pins for engagement. If required, slightly move arm to allow restraint gear and pawl to mesh. DO NOT hammer arm restraint pin down as this will damage the restraint gear teeth.

•Raise vehicle until tires clear the floor.

•Stop and check adapters for secure contact at vehicle manufacturer's recommended lift points.

• Continue to raise to desired height only if vehicle is secure on lift.

• DO NOT go near or under a raised vehicle if all four adapters are not in secure contact with vehicle at vehicle manufacturer's recommended lift points.

• Repeat entire loading and raising procedures if required.

• Lower lift onto safety locks.

TYPICAL LIFTING POINTS

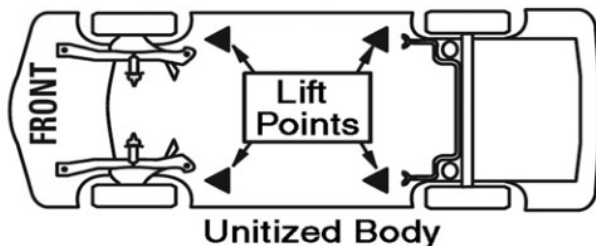
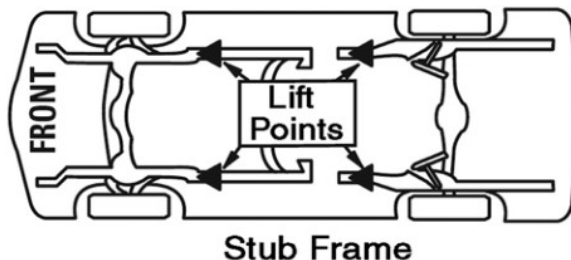
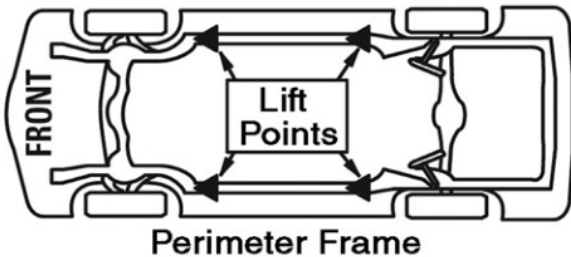
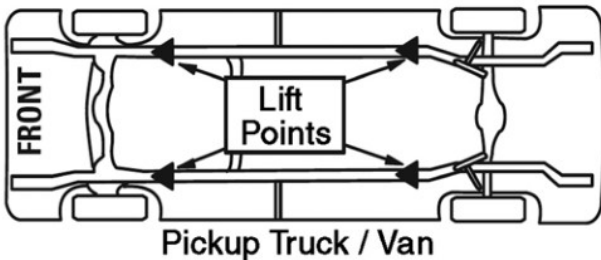

LIFT OPERATION SAFETY (CONT'D)

VISUALLY CONFIRM THAT ALL PRIMARY SAFETY LOCKS ARE ENGAGED BEFORE ENTERING WORK AREA. SUSPENSION COMPONENTS USED ON THIS LIFT ARE INTENDED TO RAISE AND LOWER LIFT ONLY AND ARE NOT MEANT TO BE LOAD HOLDING DEVICES. REMAIN CLEAR OF ELEVATED LIFT UNLESS VISUAL CONFIRMATION IS MADE THAT ALL PRIMARY SAFETY LOCKS ARE FULLY ENGAGED AND THE LIFT IS LOWERED ONTO THE SAFETY LOCKS. REFER TO INSTALLATION /OPERATION MANUAL FOR PROPER SAFETY

- DO NOT enter work area or go under vehicle if safety locks are not engaged.

- CLEAR AREA if vehicle is in danger of falling.
- DO NOT position yourself between a wall and the lift.

If the vehicle falls in that direction, you may be severely injured or killed.

- Before attempting to lift pickup trucks or other truck frame vehicles, be sure that:

- ◀ Vehicle frame is strong enough to support its weight and has not been weakened by modification or corrosion.

- ◀ Vehicle individual axle weight does not exceed one-half lift capacity.

- ◀ Adapters are in secure contact with frame at vehicle manufacturers recommended lift points.

- ◀ Vehicle is stable on lift and the center of gravity is NOT off balance.

- ◀ The overhead switch bar will contact the highest point on the vehicle.

WHILE USING LIFT

Avoid excessive rocking of vehicle while on lift.

- Always use safety stands as needed or when removing or installing heavy components.

WHEN LOWERING THE LIFT PAY CAREFUL ATTENTION THAT ALL PERSONNEL AND OBJECTS ARE KEPT CLEAR. ALWAYS KEEP A VISUAL LINE OF SITE ON THE LIFT AT ALL TIMES. ALWAYS MAKE SURE THAT ALL LOCKS ARE DISENGAGED. IF ONE OF THE LOCKS INADVERTENTLY LOCKS ON DESCENT THE LIFT AND/OR VEHICLE MAY DISRUPT CAUSING PERSONAL INJURY OR DEATH.

2. Raise lift on safety locks. Make sure you raise the lift by at least two inches to allow adequate clearance for the locks to clear.

3. Pull unlock ring

4. Push LOWERING valve handle to lower. Note: Both SAFETY LOCK release and LOWERING valve handles must be held down simultaneously to lower lift. Do not override self-closing lift controls.

5. Remain clear of lift when lowering vehicle. Observe pinch point warning decal instructions.

6. Remove adapters from under vehicle and swing arms to full drive-thru position before moving vehicle.

7. If lift is not operating properly, DO NOT use until adjustment or repairs are made by qualified lift service personnel.

MAINTENANCE INSTRUCTIONS



IF YOU ARE NOT COMPLETELY FAMILIAR WITH AUTOMOTIVE LIFT MAINTENANCE PROCEDURES; STOP AND CONTACT THE MANUFACTURER FOR INSTRUCTIONS. TO AVOID PERSONAL INJURY, PERMIT ONLY QUALIFIED PERSONNEL TO PERFORM MAINTENANCE ON THIS EQUIPMENT.

TO LOWER THE LIFT



WARNING

Make sure vehicle is neither front nor rear heavy and select the proper configuration for the vehicle to be lifted (symmetric/asymmetric) as shown below. Center of balance should be midway between adapters

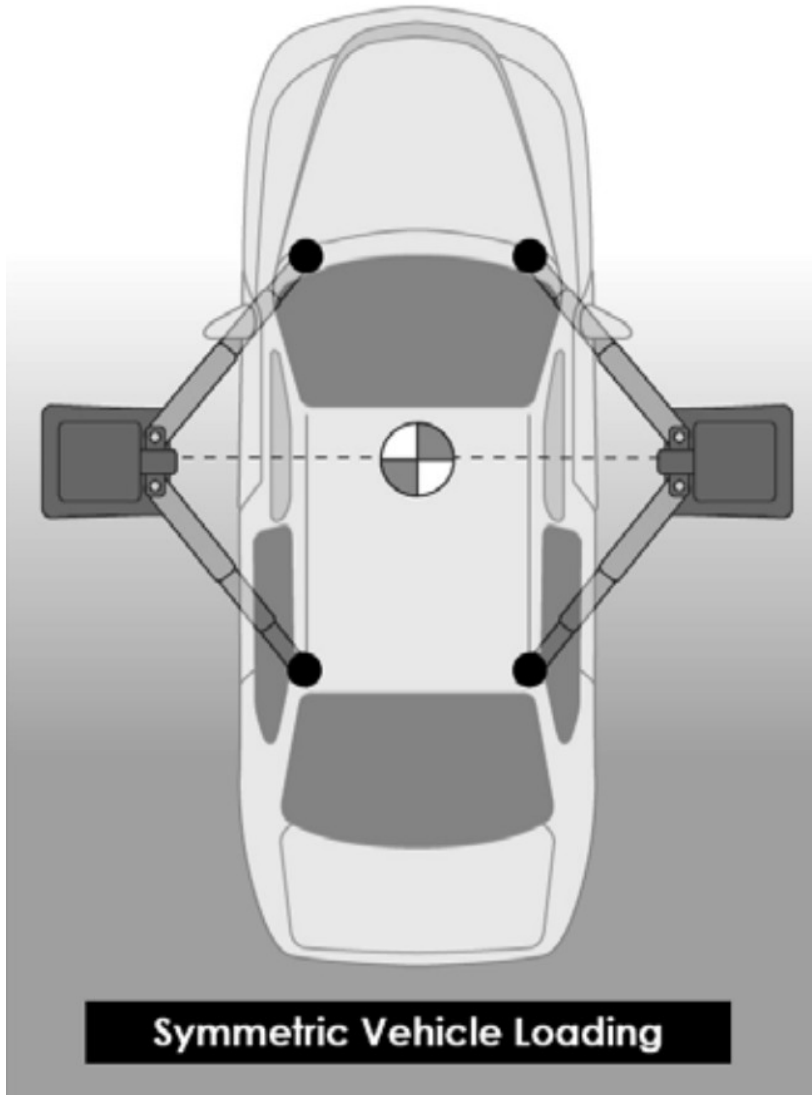

- Always replace ALL FAULTY PARTS before lift is put back into operation.
- Daily: Make a visual inspection of ALL MOVING PARTS and check for excessive signs of wear.
- Daily: Check safety locks to ensure they are in good operating condition.
- Daily: Check cables and sheaves for wear. Replace worn parts as required with genuine parts.
- Daily: Inspect adapters for damage or excessive wear. Replace as required with genuine parts.
- Weekly: Lubricate all sheaves and rollers with general purpose oil.
- Weekly: Check all cable connections, bolts and pins to ensure proper mounting.
- Monthly: Check equalizer cable tension. Adjust per lift installation instructions.
- Monthly: Lubricate locking latch shafts. Push latch handle several times for oil to penetrate pivot points.
- Every 3 Months: Check anchor bolt torque. Anchors should be torqued to 90 ft/lbs.
- Semi-Annually: Check fluid level of lift power unit and refill if required per lift installation instructions.

TO RAISE LIFT

- ◀ Read operating and safety manuals before using lift.
- ◀ Always lift a vehicle according to the manufacturers recommended lifting points.

- ◀ Position vehicle between posts.
- ◀ Adjust swing arms so that the vehicle is positioned with the center of gravity midway between pads.
- ◀ Use truck adapters as needed. Never exceed 9" of pad height.
- ◀ NEVER use lift pad assemblies without rubber slip over pads in place.
- ◀ Raise the vehicle by depressing button until the vehicle just lifts off the ground. Re-check to make sure the vehicle is secure and all locking pins are lock in place.
- ◀ Raise vehicle to desired height. Lower vehicle onto nearest safety,
- ◀ Always ensure safeties are engaged before any attempt is made to work on or near vehicle.

TO LOWER THE LIFT

- ◀ First raise the lift clear to the safeties.
- ◀ Release safeties by pulling on the safety **Unlock Pull Ring**.
- ◀ Be sure tool trays, stands or personnel are cleared from under the vehicle.
- ◀ Lower vehicle by activating lowering handle on power unit.
- ◀ Before removing vehicle from lift; position lift arms and supports to provide an unobstructed exit.
- ◀ NEVER, drive over lift arms.

REQUIRED MONTHLY MAINTENANCE

- ◀ Check all arm adjusting locks for proper operation.
- ◀ Check all cables connections, bolts and pins to ensure proper mounting and torque.
- ◀ Visually inspect safeties for proper operation.
- ◀ Lubricate posts with grease.
- ◀ Inspect all anchors bolts and retighten if necessary.
- ◀ Check all posts for squareness and plumb.
- ◀ Inspect all pivot arms pins making sure they are properly secure.
- ◀ Check equalizer cable tension, and adjust if necessary.
- ◀ If lift is equipped with overhead micro switch, check for proper operation.



1. **WARNING:** If cement anchor bolts are loose or any component of the lift is found to be defective, **DO NOT USE THE LIFT.**
2. Never operate the lift with any person or equipment below the vehicle.
3. Never exceed the rated lift capacity.
4. Always ensure the safeties are engaged before any attempt is made to work on or near the vehicle.
5. Never leave lift in elevated position unless the safeties are engaged.
6. Do not permit electric motor to get wet! Motor damage caused by dampness is not covered under warranty



NEVER LIFT ANY VEHICLE IN ANY MANNER WITH LESS THAN ALL FOUR (4) ARMS. RATED CAPACITY OF EACH LIFT ARM IS NO GREATER THAN ONE FOURTH (1/4) OF THE OVERALL LIFT CAPACITY.



WIRE ROPE INSPECTION AND MAINTENANCE

- ◀ Lifting cables should be replaced every three - five years or when visible signs of damage are apparent.

DO NOT USE LIFT WITH DEFECTIVE / WORN CABLES.

◀ Lifting cables should be maintained in a well-lubricated condition at all times. Wire rope is only fully protected when each wire strand is lubricated both internal and external. Excessive wear will shorten the life of the wire rope. The factory suggested wire rope lubricant that penetrates to the core of the rope and provides long-term lubrication between each individual strand is 90-WT gear oil Wire Rope Lubricant. In order to make sure that the inner layers of the rope remain well lubricated, lubrication should be carried out at intervals not exceeding three months during operation.

◀ All sheaves and guide rollers in contact with the moving rope should be given regular visual checks for surface wear and lubricated to make sure that they run freely. This operation should be carried out at appropriate intervals generally not exceeding three months during operation. For all sheave axles, the factory recommends standard wheel bearing grease.

For all sheaves and/or guide rollers, the factory recommends 90-WT gear oil or similar heavy lubricant applied by any method including pump / spray dispensing, brush, hand and/or swabbing.

HOW OFTEN TO INSPECT

◀ Lifting cables should be visually inspected at least once each day when in use, as suggested by American Petroleum Institute (API) RP54 guidelines.

◀ Any lifting cables that have met the criteria for removal must be immediately replaced.

WHEN TO REPLACE LIFTING CABLES DUE TO BROKEN WIRES

◀ Lifting cables should be removed from service when you see six randomly distributed broken wires within any one lay length, or three broken wires in one strand within one lay length.

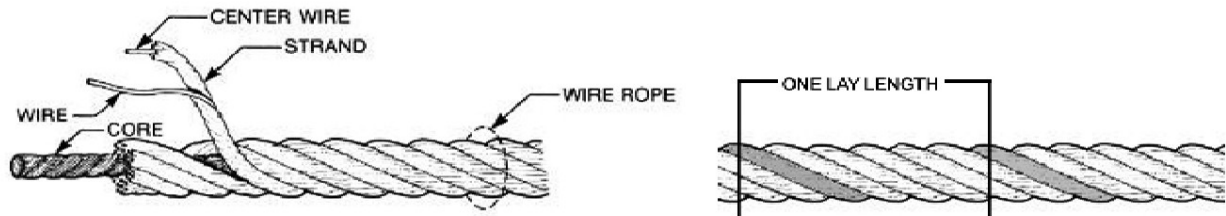

The three basic components of a typical wire rope.

OTHER REASONS TO REPLACE LIFTING CABLES

- ◀ Corrosion that pits the wires and/or connectors.
- ◀ Evidence of kinking, crushing, cutting, bird-caging or a popped core.
- ◀ Wear that exceeds 10% of a wire's original diameter.
- ◀ Evidence of heat damage.

HOW TO FIND BROKEN WIRES

◀ The first step is to relax your rope to a stationary position and move the pick-up points off the sheaves. Clean the surface of the rope with a cloth — a wire brush, if necessary — so you can see any breaks.

◀ Flex the rope to expose any broken wires hidden in the valleys between the strands.

◀ Visually check for any broken wires. One way to check for crown breaks is to run a cloth along the rope to check for possible snags.

◀ With an awl, probe between wires and strands and lift any wires that appear loose. Evidence of internal broken wires may require a more extensive rope examination.

Safe Lift Operation

Automotive and truck lifts are critical to the operation and profitability of your business. The safe use of this and other lifts in your shop is critical in preventing employee injuries and damage to customer's vehicles. By operating lifts safely

you can ensure that your shop is profitable, productive and safe.

Safe operation of automotive lifts requires that only trained employees should be allowed to use the lift.

TRAINING SHOULD INCLUDE, BUT NOT LIMITED TO:

- ◀ Proper positioning of the vehicle on the lift arms. (See manufacturers minimize wheel base loading requirements.)
 - ◀ Use of the operating controls.
 - ◀ Understanding the lift capacity.
 - ◀ Proper use of jack stands or other load supporting devices.
 - ◀ Proper use, understanding and visual identification of safety lock devices and their operation.
 - ◀ Reviewing the safety rules.
 - ◀ Proper housekeeping procedures (lift area should be free of grease, oil, tools, equipment, trash, and other debris).
 - ◀ A daily inspection of the lift should be completed prior to its use. Safety devices, operating controls, lift arms and other critical parts should be inspected prior to using the lift.
 - ◀ All maintenance and repairs of the lift should be completed by following the manufacturer's requirements.
- Lift repair parts should meet or exceed OEM specifications. Repairs should only be completed by a qualified lift technician.
- ◀ The vehicle manufacturer's recommendations should be used for spotting and lifting the vehicle

LIFT OPERATION / SAFETY

- ◀ It is important that you know the load limit. Be careful that you do not overload the lift. If you are unsure what the load limit is, check the data plate found on one of the lift columns or contact the manufacturer.
- ◀ The center of gravity should be followed closely to what the manufacturer recommends.
- ◀ Always make sure you have proper overhead clearance. Additionally, check that attachments, (vehicle signs, campers, antennas, etc.) are not in the way.
- ◀ Be sure that prior to the vehicle being raised, the doors, trunk, and hood are closed securely.
- ◀ Prior to being raised, make sure there is no one standing closer than six feet from the lift.
- ◀ After positioning the vehicle on the lift runways, set the emergency brake, make sure the ignition is off, the doors are closed, overhead obstructions are cleared, and the transmission is in neutral.
- ◀ Double check that the automatic chock devices are in position and then when the lift is raised, observe the chocks.
- ◀ Put pads or adapters in the right position under the contact points that have been recommended.
- ◀ The lift should be raised just until the vehicle's wheels are about one foot off the ground. If contact with the vehicle is uneven or it appears that the vehicle is not sitting secure, carefully lower the lift and readjust.
- ◀ Always consider potential problems that might cause a vehicle to slip, i.e., heavy cargo, undercoating, etc.
- ◀ Pay attention when walking under a vehicle that is up on the hydraulic lift.



- DO NOT leave the controls while the lift is still in motion.
- DO NOT stand directly in front of the vehicle or in the bay when vehicle is being loaded or driven into position.
- DO NOT go near vehicle or attempt to work on the vehicle when being raised or lowered.
- REMAIN CLEAR of lift when raising or lowering vehicle.
- DO NOT rock the vehicle while on the lift or remove any heavy component from vehicle that may cause excessive weight shift.
- DO NOT lower the vehicle until people, materials, and tools are clear
- ALWAYS ENSURE that the safeties are engaged and lowered on to the safeties before any attempt is made to work on or near vehicle.
- Some vehicle maintenance and repair activities may cause the vehicle to shift. Follow the manufacturer's guidelines when performing these operations. The use of jack stands or alternate lift points may be required when completing some repairs.
- READ AND UNDERSTAND all safety warning procedures before operating lift.
- KEEP HANDS AND FEET CLEAR. Remove hands and feet from any moving parts. Keep feet clear of lift when lowering. Avoid pinch points.
- ONLY TRAINED OPERATORS should operate this lift. All non-trained personnel should be kept away from work area. Never let non-trained personnel come in contact with, or operate lift.
- USE LIFT CORRECTLY. Use lift in the proper manner. Never use lifting adapters other than what is approved by the manufacturer.
- DO NOT override self-closing lift controls.
- CLEAR AREA if vehicle is on danger of falling.
- STAY ALERT. Watch what you are doing. Use common sense. Be aware.
- CHECK FOR DAMAGED PARTS. Check for alignment of moving parts, breakage of parts or any condition that may affect its operation. Do not use lift if any component is broken or damaged.
- NEVER remove safety related components from the lift. Do not use lift if safety related components are damaged or missing.
- When the lift is being lowered, make sure everyone is standing at least six feet away.
- Be sure there are no jacks, tools, equipment, left under the lift before lowering.
- Always lower the vehicle down slowly and smoothly

LIFT WILL NOT RAISE

POSSIBLE CAUSE

1. Air in oil, (1,7,12)
2. Cylinder binding, (8)
3. Cylinder leaks internally, (8)
4. Motor run backward under pressure, (10)
5. Lowering valve leaks, (2,3,5,9,10)
6. Motor runs backwards, (6,7,10)
7. Pump damaged, (9,10)
8. Pump won't prime, (1,7,12,13,2,11,9,10)
9. Relief valve leaks, (9,10)
10. Voltage to motor incorrect, (6,13,10)

REMEDY INSTRUCTION

1. Check for proper oil level. The oil level should be up to the bleed screw in the reservoir with the lift all the way down.
2. Flush release valve to get rid of. Hold release handle down and start unit allowing possible contamination it to run for 15 seconds.
3. Dirty oil. Replace oil with clean Dexron ATF.
4. Tighten all fasteners. Tighten fasteners to recommended torques.
5. Check for free movement of release. **If Unlock Pull Ring does not move freely, replace Safety Lock Assembly assembly.**
6. Check if motor is wired correctly. wired correctly explain
7. Oil seal damaged or cocked Replace oil seal around pump shaft.
8. See Installation Manual Contact Factory
9. Replace with new part Replace with new part.
10. Return unit for repair Return unit for repair.
11. Check pump-mounting bolts Bolts should be 15 to 18 ft. lbs.
12. Inlet screen clogged Clean inlet screen or replace.
13. Check wall outlet voltages and wiring Make sure unit and wall outlet are wired properly.

LIFT LOWERS SLOWLY OR NOT AT ALL

POSSIBLE CAUSE

1. Cylinders binding, (1)
2. Release valve clogged, (5,4,2,3)
3. Pressure fitting too long, (6)

REMEDY INSTRUCTION

1. Contact Customer Support. Contact Customer Support.
2. Replace with new part Replace with new part.
3. Return for repair Return for repair.
4. Check oil. Use clean 10-WT hydraulic oil or Dexron automatic transmission fluid only. If ATF is contaminated, replace with clean ATF and clean entire system.
5. Clean release valve Wash release valve in solvent and blow out with air.
6. Replace fitting with short thread lead Replace fitting with short thread lead.

WILL NOT RAISE LOADED LIFT

POSSIBLE CAUSE

1. Air in oil, (1,2,3)
2. Cylinder binding, (4)
3. Cylinder leaks internally, (4)
4. Lift overloaded, (5,4)
5. Lowering valve leaks, (6,7,1,4,8)
6. Motor runs backwards, (9,11,8)
7. Pump damaged, (4,8)
8. Pump won't prime, (1,2,3,4,10,8)
9. Relief valve leaks, (7,4,8)
10. Voltage to motor incorrect, (9,11,4)

REMEDY INSTRUCTION

1. Check oil level The oil level should be up to the bleed screw in the reservoir with the lift all the way down.
2. Check/Tighten inlet tubes Replace inlet hose assembly.
3. Oil seal damaged or cocked Replace oil seal and install.
4. See Installation Manual Contact Customer Support.
5. Check vehicle weight Compare weight of vehicle to weight limit of the lift.
6. Flush release valve Hold release handle down and start unit allowing it to run for 15 seconds.
7. Replace with new part Replace with new part.
8. Return unit for repair Return unit for repair.
9. Check motor is wired correctly Compare wiring of motor to electrical diagram on power unit drawing.
10. Inlet screen clogged Clean inlet screen or replace.
11. Check wall outlet voltage and wiring Make sure unit and wall outlet is wired properly.

IMPORTANT

If after observing that all mechanical locks are released and the lift still fails move following all standard operating procedures, immediately stop using the lift and contact factory or factory approved service center for further instructions.

LIFT WILL NOT STAY UP

POSSIBLE CAUSE

1. Air in oil, (1,2,3)
2. Check valve leaks, (6)
3. Cylinders leak internally, (7)
4. Lowering valve leaks, (4,5,1,7,6)
5. Leaking fittings, (8)

REMEDY INSTRUCTION

1. Check oil level The oil level should be up to the bleed screw in the reservoir with the lift all the way down.
2. Oil seal damaged and cocked Replace oil seal around pump shaft.
3. Bleed cylinder Refer to Installation Manual.
4. Flush release valve Hold release handle down and start unit allowing it to run for 15 seconds.
5. Replace with new valve Replace with new valve.
6. Return unit for repair Return unit for repair.
7. See Installation Manual Contact Customer Support.
8. Check complete hydraulic system for leaks. Tighten all hydraulics fittings and inspects all hoses.

Limite switch electrical connection diagram(220V motor)

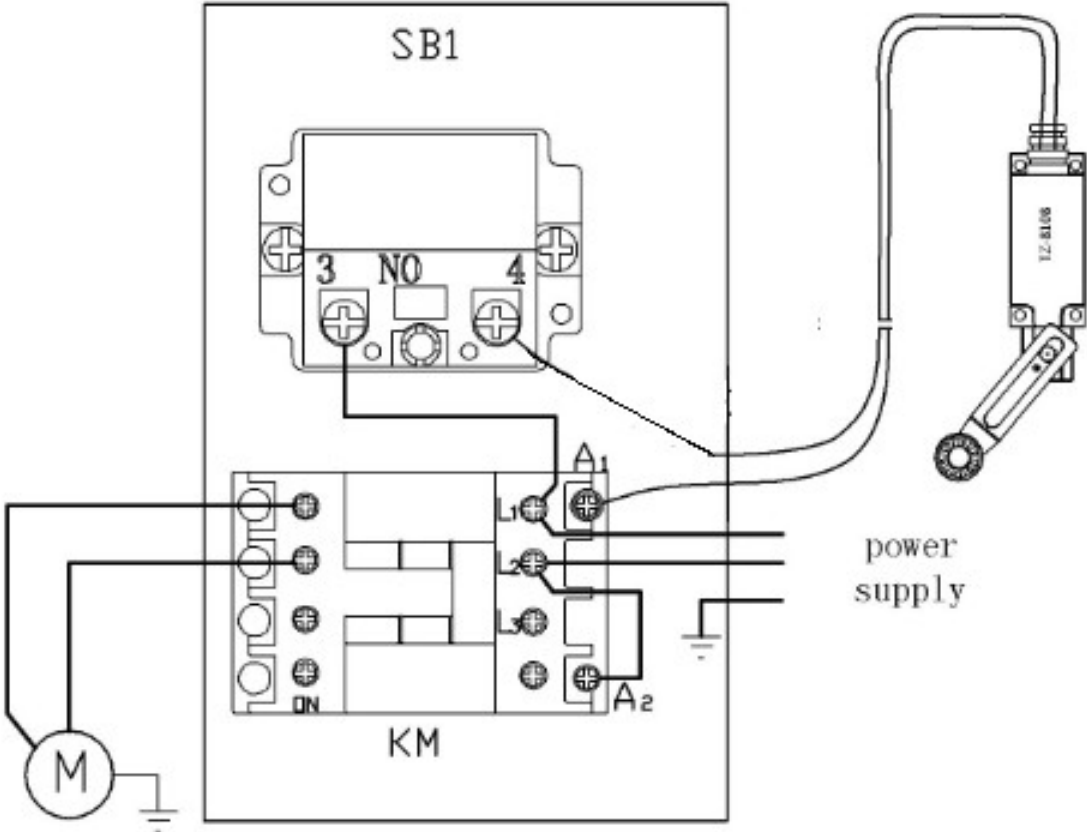
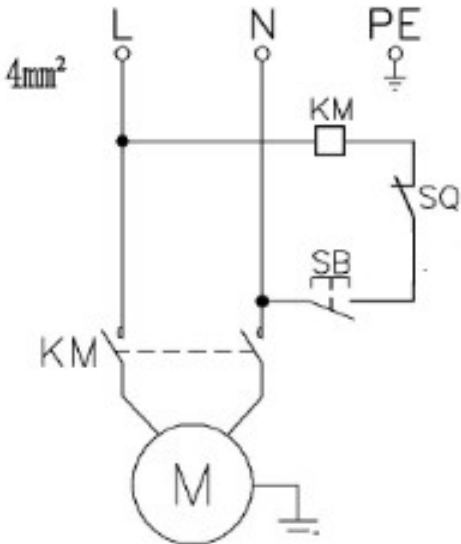

Limite switch electrical connection diagram(380V motor)

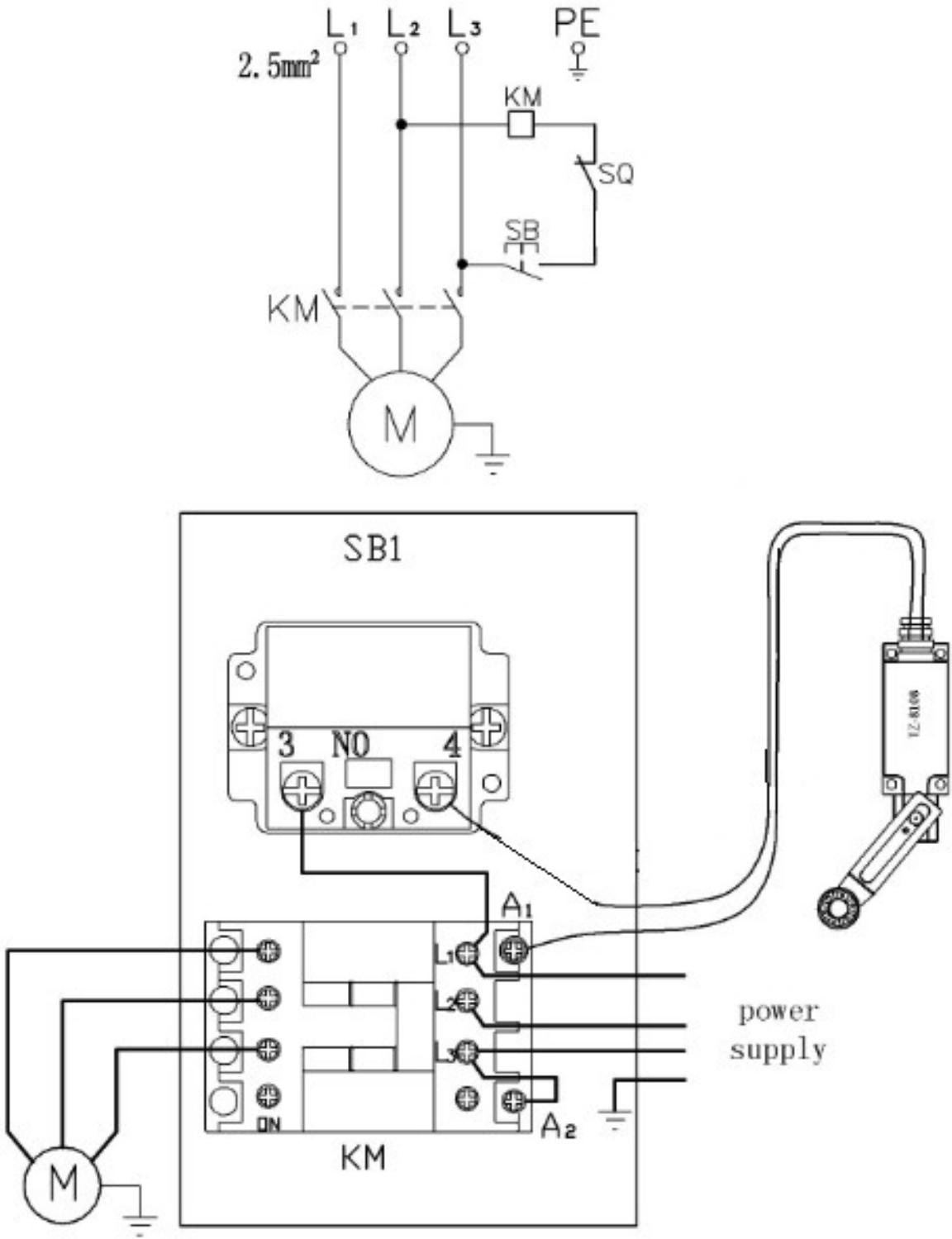

Motor Function Analysis

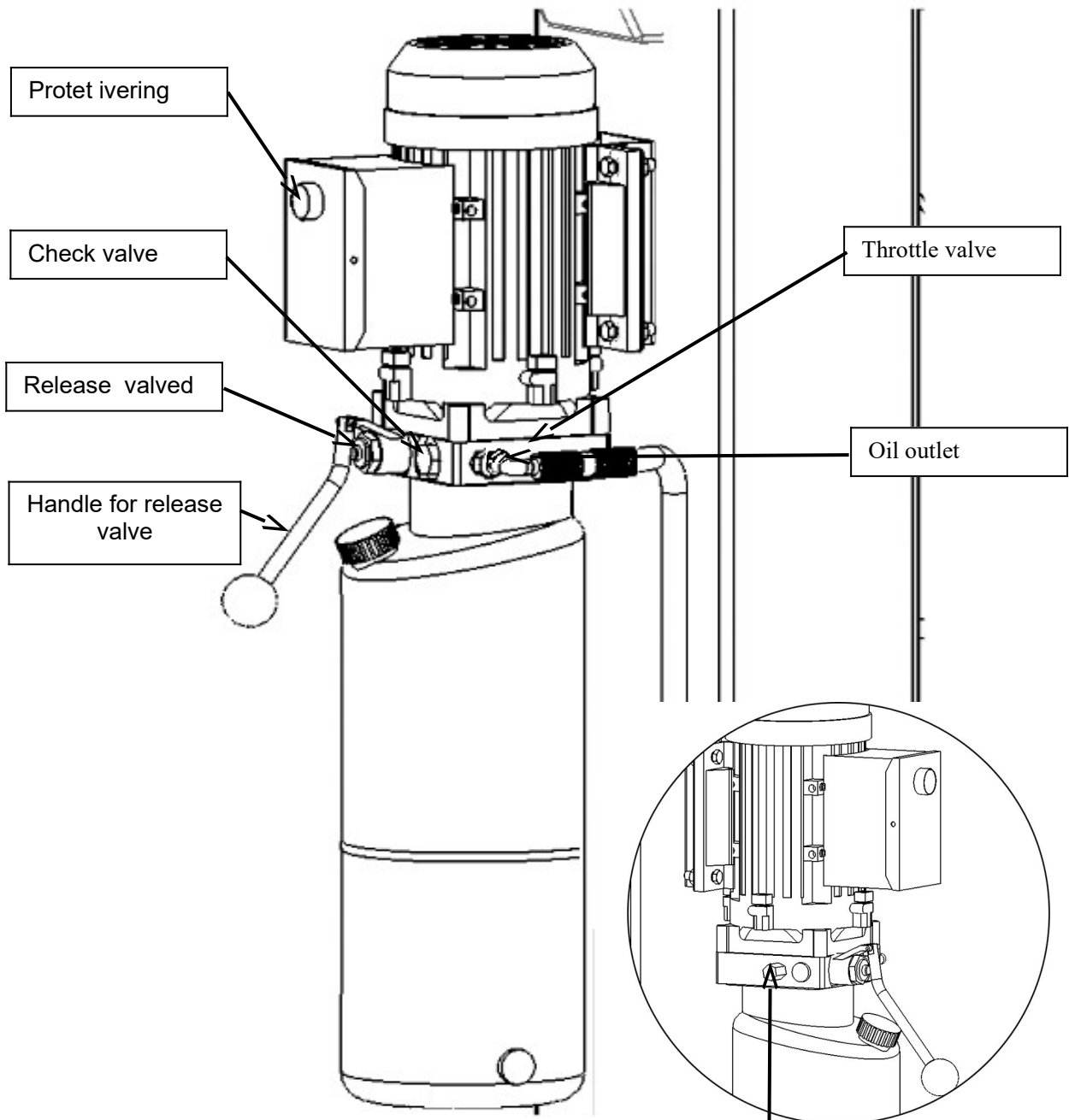

Check valve :Prevent reverse flow of oil
Overflow valve :Adjusting oil pressure
Throttle valve :Adjusting the descent rate

Motor drawing and part list

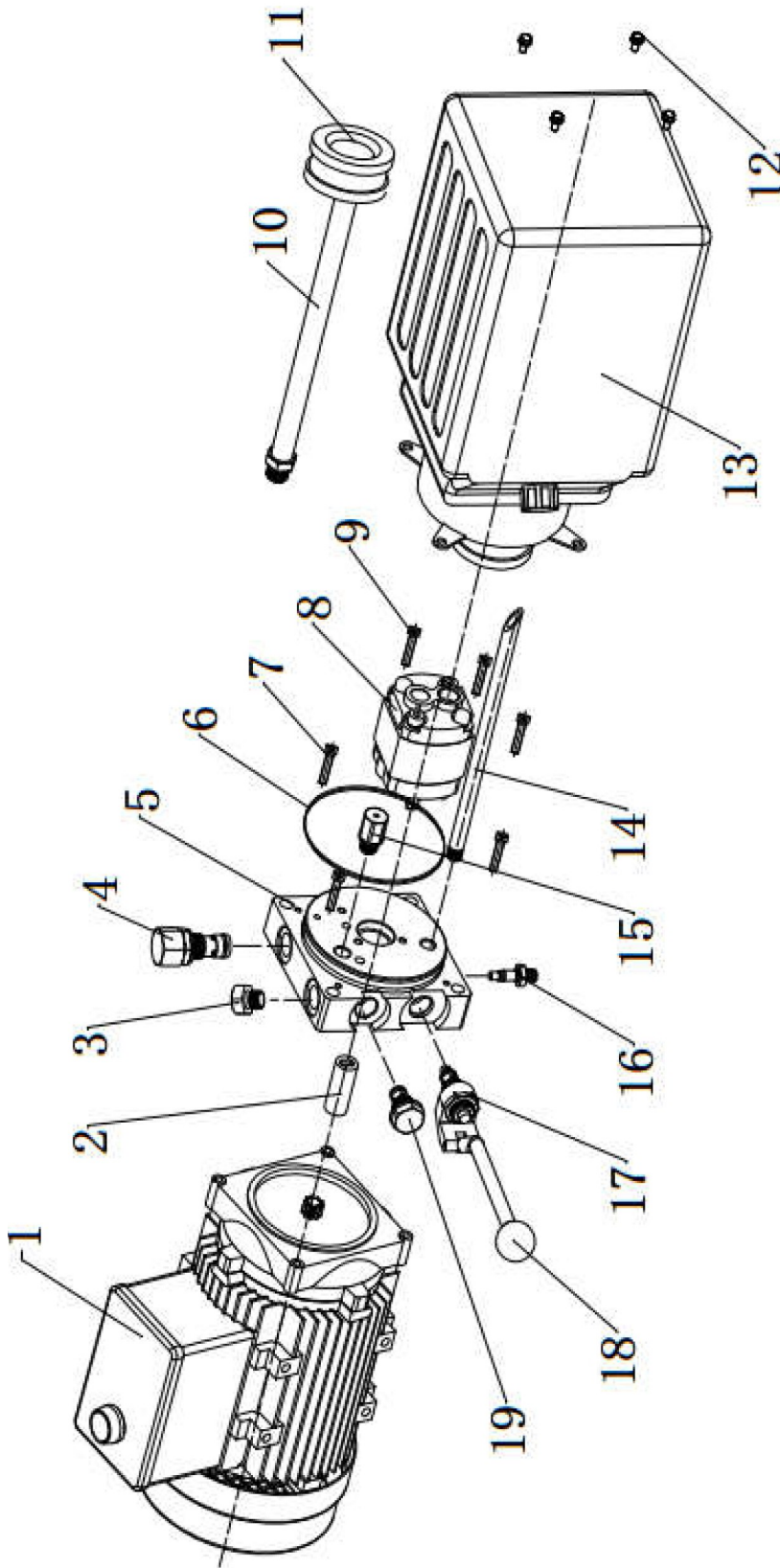

Nos.	Name	Quantity
1	Iron motor	1
2	Motor connecting shaft	1
3	Valve block blockage	1
4	Overflow valve	1
5	Valve Body	1
6	O-Ring	1
7	Valve Body Bolt	4
8	Gear Pump	1
9	Gear Pump Bolt	2
10	Oil Inlet Pipe	1

Nos.	Name	Quantity
11	Filter	1
12	Socket bolt	4
13	oil storage tank	1
14	Oil Return Pipe	1
15	Buffer Valve	1
16	Throttle valve	1
17	Release valved	1
18	Handle for release valve	1
19	Check valve	1
20		

001 Drawing and part list

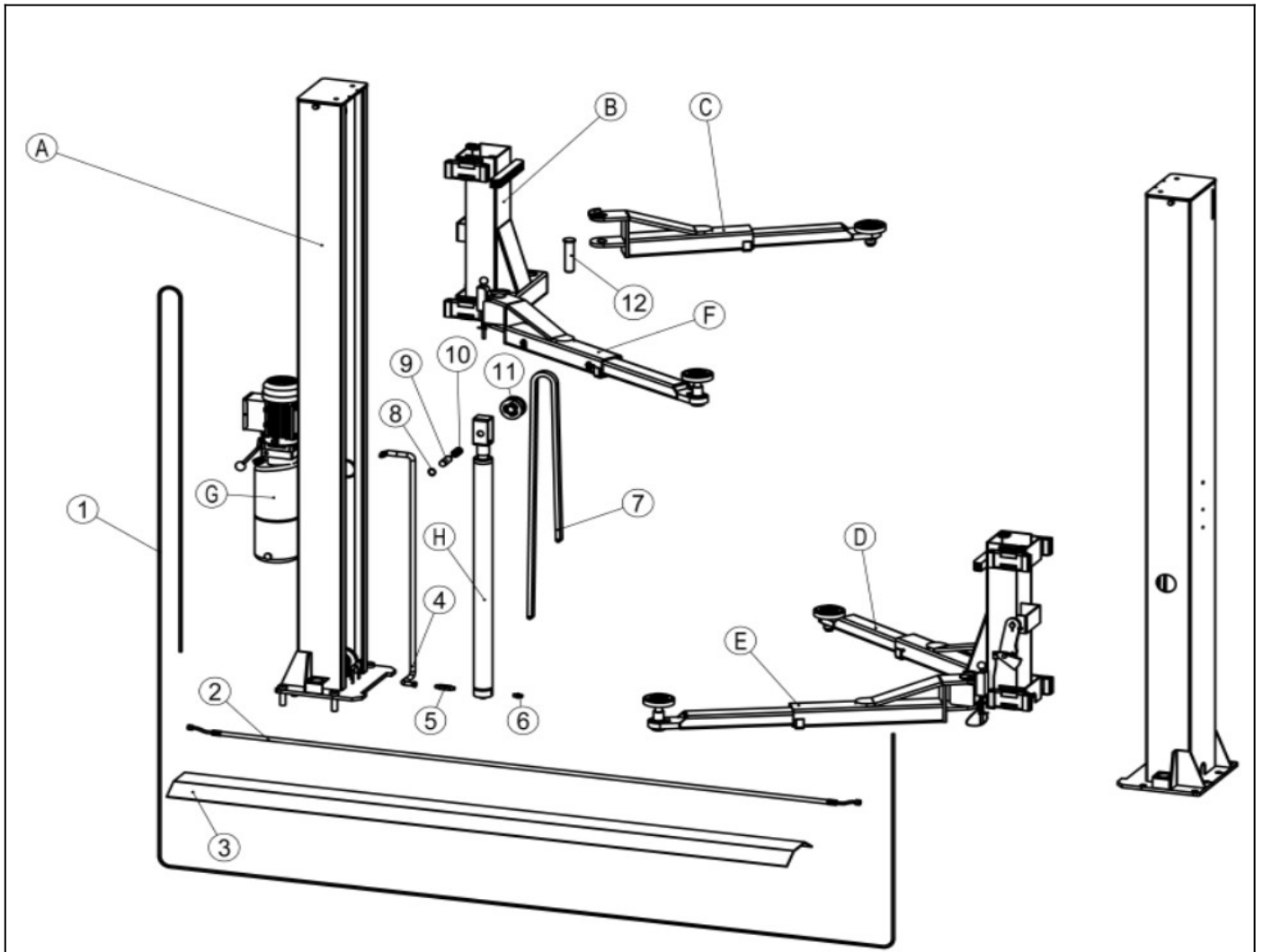

A	001-A	Main column assy	2	3	25	Asie board	3
B	001-B	Carriage assembly	2	4	YL-SBSZ-00-26	Pump oil tube assy Φ8X1040,fitting M16X15	1
C	001-C	Tow stages arms assy	1	5	YL-SBSZ-00-27	M16X1.5 length 110	1
D	001-D	Tow stages arms assy	1	6	YL-SBSZ-00-28	M16X1.5 length50	2
E	001-E	Tow stages arms assy	1	7	YL-SBSZ-00-29	Chain /LH1244/121joints	2
F	001-F	Tow stages arms assy	1	8	RE002500	Retaining ring externalΦ25	4
G	001-G	Pump assy	1	9	SF25-40	Bronze bush for chain pulley SF25-40	2
H	001-H	Hydraulic cylinder assy	2	10	YL-SBSZ-00-20	Shaft for chain pulley 35X90	2
1	YL-SBSZ-00-23	Equalizing cable assy Φ8X8640,thread head M16	2	11	YL-SBSZ-00-21	Chain Pulley	2
2	YL-SBSZ-00-24	OIL tube assy to main cylinder Φ8X2800/M16X1.5&"Q"sh ape fitting	1	12	YL-SBSZ-00-22	Arm fix shaft	4

001-B Inner arm carriages and outer arm carriages

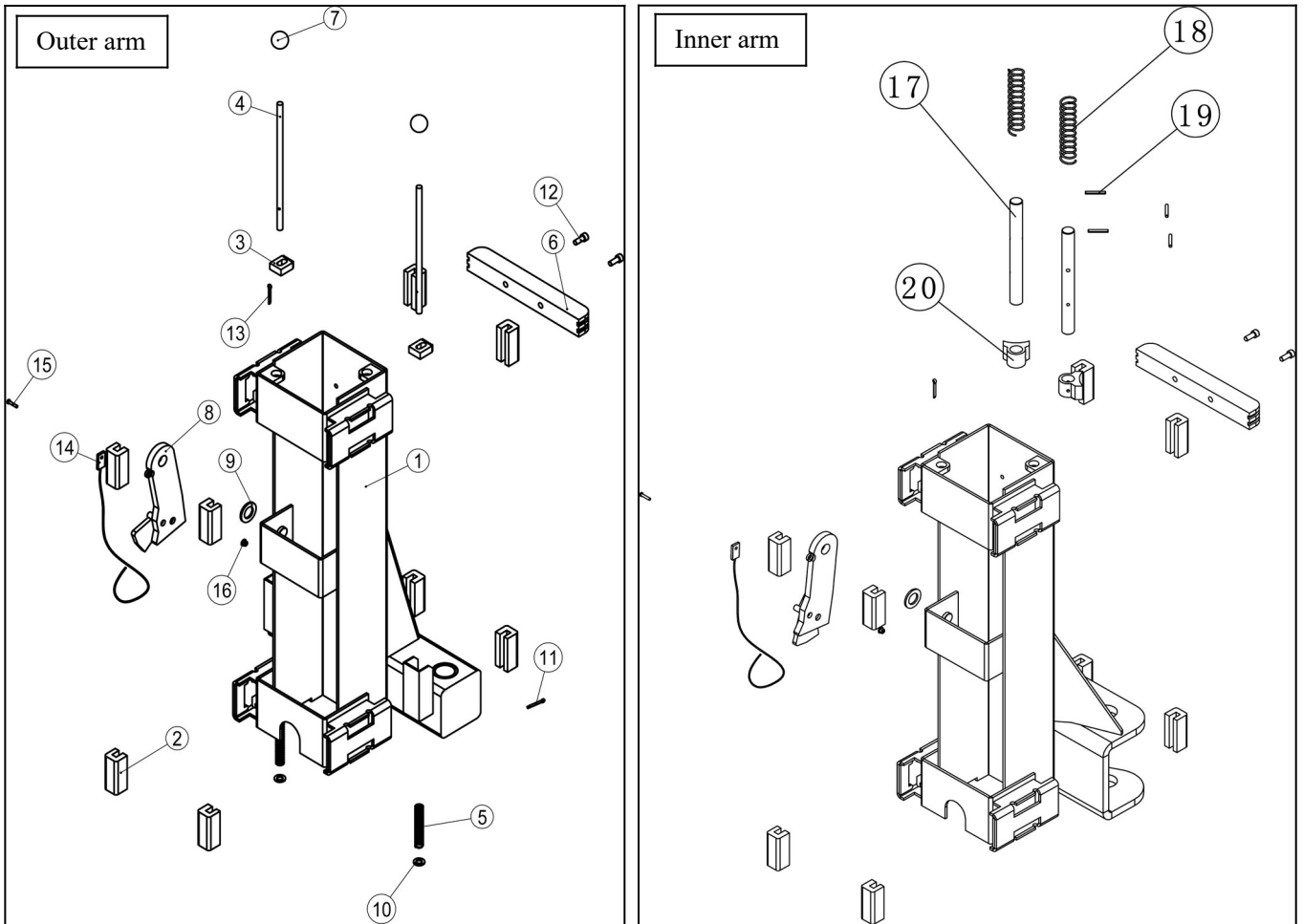

Nos.	Part Nos.	Name	Quantity	Nos.	Part Nos.	Name	Quantity
------	-----------	------	----------	------	-----------	------	----------

1	YL-SBSZ-02-01-00	Carriage weldment	2	11	SP000330	Split Pin or expansion pin Φ3X30	4
2	YL-SBSZ-00-04	UHMW polyethylene Slider block	16	12	SH000825	Sunk Head boltM8X25	4
3	YL-SBSZ-00-05	Locked teeth block	4	13	YL-SBSZ-00-11	circlip (B-shape)	2
4	YL-SBSZ-00-06	Unlock lever	4	14	YL-SBSZ-00-12	Unlock — rope	2
5	YL-SBSZ-00-07	lock rod spring	4	15	IH000820	Inside Hex bott /M8X20	2
6	YL-SBSZ-00-08	Prote ctive rubber	2	16	HN000800	Hex nut M8	2
7	YL-SBSZ-00-09	Handle ball	4	17	YL-SBSZ-00-30	Arm fix shaft	4
8	YL-SBSZ-00-10	lock	2	18	SS261402	lock springΦ26/140/Φ2	4
9	W002500	Washer Φ25	2	19	S000532	Straight pinΦ5x32	8
10	W001000	Washer Φ10	4	20	YL-SBSZ-00-31	Locked teeth block	4

001-C 2-segment arm (outer arm)

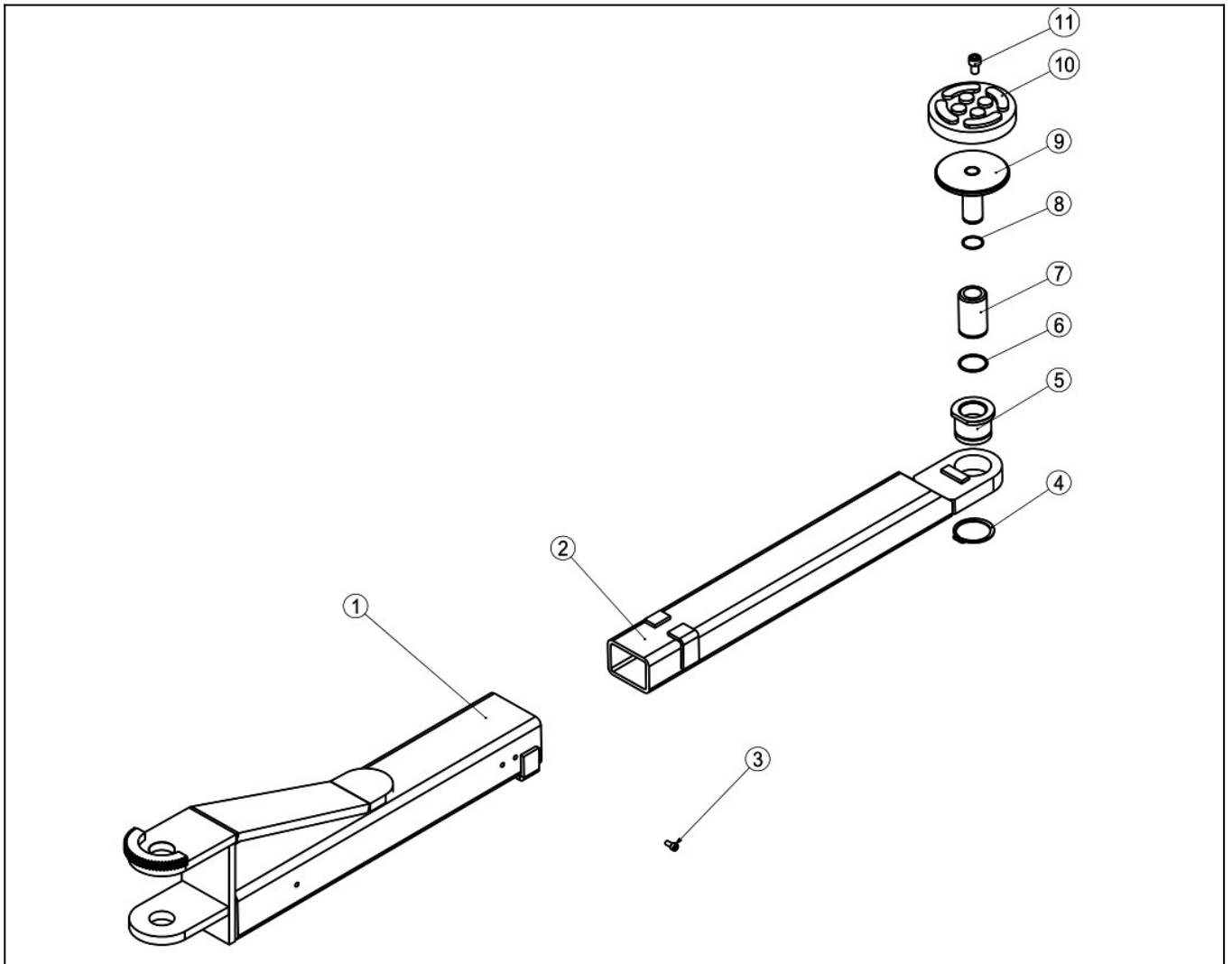

Accurate view by actual purchase order

Nos.	Part Nos.	Name	Quantity
1	YL-SBSZ-03-01-00	Inner arm of two stage arms	4
2	YL-SBSZ-03-02-00	outer arm of two stage arms	4
3	IH000810	Inside Hex bott /M8X10	4
4	RE005000	Retaining ring externalΦ50	4
5	YL-SBSZ-00-14	Sleeve of one stage screwed pad	4
6	YL-SBSZ-00-15	steel wire-circlip	4
7	YL-SBSZ-00-16	Extension	4
8	YL-SBSZ-00-17	steel wire-circlip	4
9	YL-SBSZ-00-18	Screwed pad	4
10	YL-SBSZ-00-19	Rubber cover	4

KRAFT&DELE

DECLARATION OF CONFORMITY

According to ISO/IEC Guide 22 and EN 45014

Manufacturer: Foreintrade S.A

Manufacturer's address: Janówek, ul. Modrzewiowa 54 05-555 Tarczyn

WE DECLARE THAT THE PRODUCT IS COMPLIANT WITH EUROPEAN STANDARDS

Product name: Two post car lift (marked with the Kraft&Dele trademark)

Model (trade designations): KD5816

Declaration:

The product to which this declaration refers meets the requirements of EC Directives:

1. 2006/42/EC Machinery Directive

According to standards:

EN ISO 12100:2010; EN 60204-1:2018; EN 1493:2010

Person responsible for maintaining technical documentation: Ma Dong Hui, Janówek, ul. Modrzewiowa 54 05-555 Tarczyn

Ma Dong Hui, Tarczyn, 01.01.2025

Foreintrade S.A
Janówek, ul. Modrzewiowa 54
05-555 Tarczyn
NIP: 521-36-70-752; Regon: 147383292



