

KD5841

Wheel Balancer User Manual KD5841



TABLE OF CONTENTS

1. REFACE	1
1.1 WARNING	1
1.2 INTRODUCTION	1
1.3 INSTALLATION REQUIREMENT.....	1
1.4 SAFETY REGULATIONS	2
1.5 MEANING OF THE DECALS	3
1.6 SAFETY LABEL POSITION DIAGRAM	3
2. INSTALLATION	4
2.1 PROTECTIVE HOOD INSTALLATION	4
2.2 MAINSHAFT INSTALLATION	4
2.3 ELECTRIC CONNECTION & EARTHING	4
3. TECHNICAL CHARACTERISTICS	5
3.1 CHARACTERISTICS	5
3.2 MAIN TECHNICAL SPECIFICATION	5
3.3 WORKING PRINCIPLE	5
4. TRANSPORTATION & INSTALLATION	6
4.1 TRANSPORTATION	6
4.2 INSTALLATION	7
5. SAFETY & PREVENTION	8
6. EQUIPMENT STRUCTURE	9
6.1 MAIN STRUCTURE.....	9
6.2 DISPLAY PANEL & CONTROL PANEL	10
6.3 ACCESSORY	11
7. OPERATION	12
7.1 MACHINE STARTUP	12

7.2 WHEEL MOUNGTING	12
7.3 BALANCE MODE SELECT	13
7.4 VALUE INPUT	13
7.5 SPIN THE WHEEL	14
7.6 PLACING WEIGHTS	14
7.7 RESIDUAL UNBALANCE VALUE DISPLAY	14
7.8 OPTIMIZED COINCIDENCE BALANCE OPERATION	14
8. PROGRAM SETUP	15
8.1 MACHINE PARAMETER SETUP	15
8.2 UNIT CONVERSION	16
8.3 SELF CALIBERATION	16
9. TROUBLE SHOOTING	17
9.1 ERROR INDICATION	17
9.2 FREQUENT ERRORS AND SOLUTIONS	17
10. MAINTENANCE	18
APPENDIX.....	21
WARRANTY	22

1. PREFACE

1.1 WARNING

There will be one year of warranty period on the condition that the machine including the operation system , tools and accessories are used properly and/or without damage. During this period, the manufacturer will repair or replace the parts returned or the machine itself, sustaining the costs but not accepting responsibility for normal wear and tear, incorrect use or transportation, or failure to carry out maintenance. The manufacturer will not inform the customer about any improvements to the products or the upgrading of the production line.

1.2 INTRODUCTION

The purpose of this manual is to provide the owner and operator of this machine with a set of safe and practical instructions for the use and maintenance of the wheel balancer.

If such instructions are carefully followed, the machine will offer you the levels of efficiency and duration.

The following paragraphs define the levels of danger regarding the machine.



DANGER: Refers to immediate danger with the risk of serious injury or death.



WARNING: Dangers or unsafe procedures that can cause serious injury or death.



ATTENTION: Dangers or unsafe procedures that can cause minor injuries or damage to property.

Read these instructions carefully before using the machine. Keep this manual and the illustrated materials supplied with the equipment in a folder near the place of operation

so as to allow the machine operators to consult the documentation at any time.

The manual is only to be considered valid for the machine serial number and model stated on the attached nameplate.

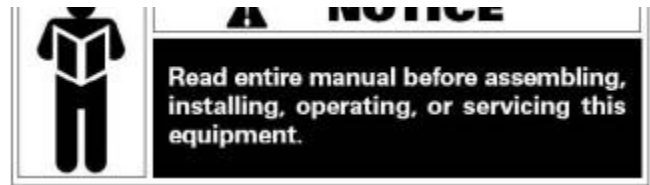

The instructions and information described in this manual must always be complied with: the operator will be held responsible for any operation not specially described and authorized in this manual.

Some of the illustrations contained in this booklet have been taken from pictures of prototypes: standard production machines may differ slightly in certain respects. These instructions are for the attention of personnel with basic mechanical skills. We have therefore condensed the descriptions of each operation by omitting detailed instructions regarding, for example, how to loosen or tighten the fixing devices. Do not attempt to perform operations unless properly qualified or with suitable experience. If necessary, please contact an authorized Service Centre for assistance.

1.3 INSTALLATION REQUIREMENT



Take the utmost care when unpacking, assembling, lifting and setting up the machine as indicated below.

Failure to observe these instructions can damage the machine and compromise the operator's safety.

Remove the original packing materials after positioning them as indicated on the packaging.



All regulations in force concerning safety at work must be complied with when choosing the installation position.

In particular, the machine must only be installed and operated in protected environments where there is no risk of exposure to dripping.

IMPORTANT: for the correct and safe operation of the machine, the lighting level in the place of use should be at least 300 lux.

Environmental operating conditions must comply with the following requirements:

- Relative humidity ranging from 30% to 80% (without condensation);
- Temperatures ranging from 0° to +50°C.



The loor must be strong enough to support a load equal to the weight of the equipment plus the maximum load allowed.



The machine must not be operated in potentially explosive atmospheres.

1.4 SAFETY REGULATIONS



Failure to comply with the instructions and danger warnings can cause serious injuries to the operator or other persons.

Do not operate the machine until you have read and understood all the danger/warning notices in this manual.

The correct use of this machine requires a qualified and authorized operator. This operator must be able to understand the manufacturer's written instructions, be suitably trained and be familiar with the safety procedures and regulations. Operators are forbidden to use the machine under the influence of alcohol or drugs that could affect his/her physical and mental capacity.

The following conditions are essential:

- Read and understand the information and instructions described in this manual;
- Have a thorough knowledge of the features and characteristics of the machine;
- Keep unauthorized persons well clear of the working area;
- Make sure that the machine has been installed in compliance with all relevant standards and regulations in force;
- Make sure that all machine operators are suitably trained, that they are capable of using the machine correctly and safely and that they are adequately supervised during work;
- Do not touch power lines or the inside of electric motors or any other electrical equipment before making sure that they have been powered off;
- Read this booklet carefully and learn how to use the machine correctly and safely;
- Always keep this user manual in a place where it can be readily consulted and do not fail to refer to it.



Do not remove or deface the DANGER, CAUTION, WARNING or INSTRUCTION decals. Replace any missing or illegible decals. If any decals have become detached or damaged, it is possible to obtain them from your nearest reseller.

- Observe the unified industrial accident prevention regulations relating to high voltages and rotating machinery whenever the machine is in use or being serviced.
- Any unauthorized changes or modifications made to the machine automatically release the manufacturer from any liability in the case of damage or accidents resulting from such changes or modifications .





WEAR PROTECTIVE GLOVE



READ OPERATION MANUAL



WEAR PROTECTIVE GLASSES



POWER OFF THE ELECTRICAL SOURCE OF THE MACHINE DURING MAINTANCE

1.5 MEANING OF THE DECALS

(including the one indicating caution)



Lightning symbol

This decal, positioned on the back of the machine, indicates where to insert the power supply cable and warns the user to pay attention to his safety.



Warning for rotating machine part

This decal, positioned next to the balancing shaft, reminds the user that this is a rotating part and is therefore dangerous and should not be touched with the hands. The arrow indicates the rotation direction.



Grounding symbol

This decal, positioned on the rear left side of the machine, indicates where to connect the ground wire.

1.6 SAFETY LABEL POSITION DIAGRAM

Pay attention to keep the safety labels complete. When it is not clear of missing, you should change the new label.

You should let the operators see the safety labels clearly and understand the meaning of the label.

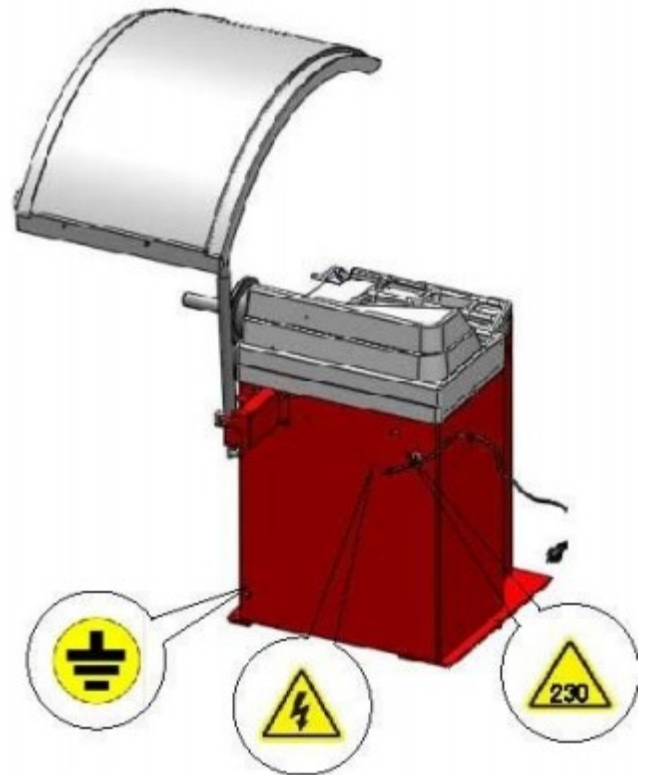

Fig. 1

2. INSTALLATION

Note: Before installation and use of the wheel balancer, you should carefully read this installation and operation manual. And keep this manual in hand for reference at any time. You should be sure that all the operators have read this manual to guarantee the most perfect functions of the machine and meanwhile the safety.

2.1 PROTECTIVE HOOD INSTALLATION

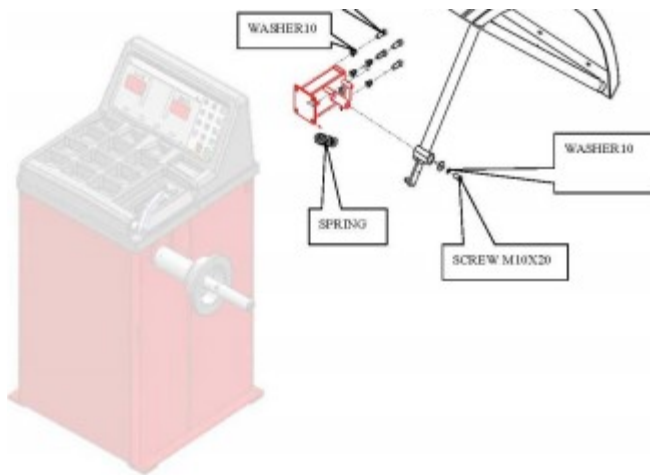

Fig. 2

2.2 MAIN SHAFT INSTALLATION

Before installation, use the ethyl alcohol and compressed air to clean up the center hole of the shaft and connect part. Use spanner and screw to fix the thread shaft on the balance shaft (Fig. 3).

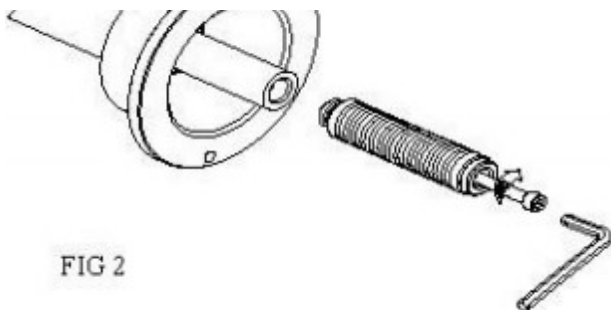

Fig. 3

2.3 ELECTRIC CONNECTION & EARTHING

According to the label on the connect between power cable and body, the power cable connect socket must be grounded with the reliable earth wire.

All the electrical devices installation must be done by the qualified staff. Before installation, please check If the power system is comply with the technical parameter marked on the nameplate of the machine. The wiring of the machine must have the fuse and the perfect ground protection. And install the electrical Leakage automatic controls switch in the power source. And recommend the application of the stabilizer if the voltage of installation site is unstable.



- *Any electrical connect in the workshop is only done by the qualified technical staffs and it should meet the enforced regulation.*
- *Any electrical connect must be according to the following:*
 - ◆ *Power on the data plate on the machine;*
 - ◆ *Voltage decrease can not exceed 4% of the rated voltage on the data plate when full load (10% when start).*
- *Operators must:*
 - ◆ *Install the plug;*
 - ◆ *Install 30ma circuit breaker;*
 - ◆ *Install power cablefuse;*
 - ◆ *Provide with effective workshop electrical connect to ground;*
- *Prevent the authorized operation and pull out the plug to prolong the working life when not use the machine.*
- *If the machine directly connected to the power source through the power board not the plug, we should use the qualified staffs to operate.*



Perfect ground is necessary for the correct operation. Do not connect the machine with air pipe, water pipe, telephone line and the other unsuitable objects.

3. TECHNICAL CHARACTERISTICS

3.1 CHARACTERISTICS

- Adopts quality computer with the feature of high intelligence and high stable
- Mechanical main shaft adopts high precision bearing driven, wear-resistant, low noise
- Press stop key to realize the emergency stop
- Full automatic dynamic/static balance check
- Balance 3 ALU rim
- Self-calibration and full automatic trouble diagnosis

3.2 MAIN TECHNICAL SPECIFICATION

3.3 WORK PRINCIPLE

The micro CPU will provide the normal information if it checks each unit in the normal situation. And the operators can execute the balance operation. When balancing, MCPU can control the rotation of the balancer tester main shaft through the drive interface. The unbalance signal sensed by balance sensor is sent to the micro-processor port through

A/D converter. CPU will integrated analyze the unbalance signal and angle signal to calculate the unbalance value and display the value through the LED unit. We can realize the man-machine talk through keyboard and LED.

4. TRANSPORTATION & INSTALLATION

4.1 TRANSPORTATION

- Place, carry and store the machine according to the indication of the label on the package carton.
- Store environment:
 - ◆ RH: 20%-95%
 - ◆ Temperature: - 10°C-+60°C
- When transport and use the machine, do not pull the rotation shaft, or it will cause the permanent damage.

Fig. 4 WORK PRINCIPLE

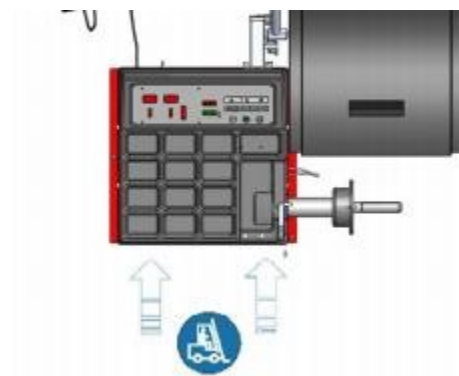

Fig. 5



Do not lift the machine at any other position.

4.1.1 After being sure that the package of your machine is perfect, you can carry the wheel balancer to the installation site. (Fig. 6). The choice of the installation should comply with the following requirements. The ambient temperature is 0°C-50°C and the RH \leq 85%. And the installation site as shown in Fig. 7.

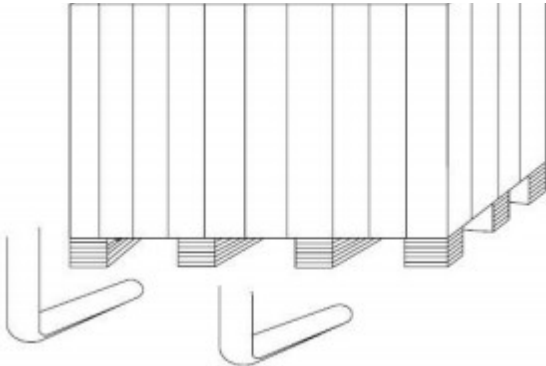

Fig. 6

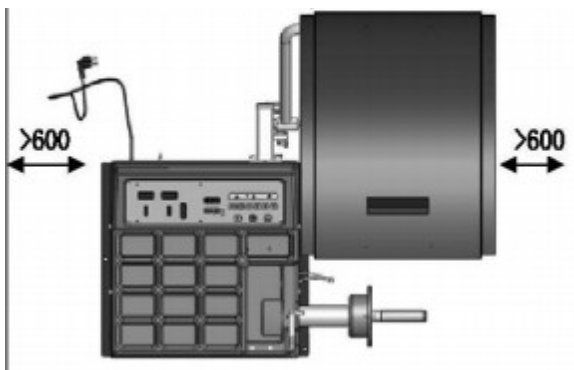

Fig. 7

4.1.2 Remove the upper cover of the package carton and check and confirm the wheel balancer, spare parts and documents you purchased according to the packing list. If you have any question, please contact with the dealer.

Package materials such as plastic, PBV, nail, screw, timber and carton must be placed into a scrap bin to treat according to the local regulation.

4.2 INSTALLATION

Remove the connect bolt. And carry down the wheel balancer to place it on the flat and solid floor. should We store it indoor to avoid it from being to the exposed sunlight for long time and the moisture.

5. SAFETY AND PREVENTION

5.1 Before operation, please confirm that you have read the entire warning label and the instruction manual. Not according with the safety instruction can cause the injuries to the operators & bystanders.

5.2 Keep your hands and the other parts of your body from the location with the potential danger. Before starting the machine, you must check it there existing the damaged part. If any break or damage, the machine will not be used.

5.3 In emergency situation, if the tire not fixed, you should press “STOP” to stop the rotation of the wheels. Adopts high strength protective cover to prevent the tire from flying in any direction and can only fall on the ground to protect the safety of the operators.

5.4 Before balancing, operators should check all the tires and wheels to find the possible faults. Do not balance the tires and wheels with fault.

5.5 Do not exceed the load capability of the wheel balancer and do not attempt to balance the wheel bigger than the designed dimension.

5.6 Wear suitable clothing such as suitable safety suit such as glove, glasses and working suit. Not wear necktie, long hair, loose clothing. The operators should stand beside the machine when operation the machine. Keep from the unauthorized personnel.

5.7 Before balancing, you must confirm the installation of the wheel suitable. Before rotation, be sure the nut turn 4turns around the thread shaft and firmly locked on the main shaft.

GENERAL CONDITIONS OF USE



The wheel balancers described in this manual must be used exclusively to measure the extent and position of car wheel unbalances, within the limits specified in the technical data section. Furthermore, models equipped with motors must be provided with a suitable guard.



Any use other than those described in this manual is to be considered improper and unreasonable.



Do not start the machine without the wheel locking equipment.



Protective hood plays the role of prevention and safety.



Do not clean or wash the wheels mounted on the machine with compressed air or jets of water.



Get to know your machine. The best way to prevent accidents and obtain top performance from the machine is to ensure that all operators know how the machine works.



Learn the function and location of all the controls.



Carefully check that all controls on the machine are working properly.



The machine must be installed properly, operated correctly and serviced regularly in order to prevent accidents and injuries.

6. EQUIPMENT STRUCTURE

6.1 MAIN STRUCTURE

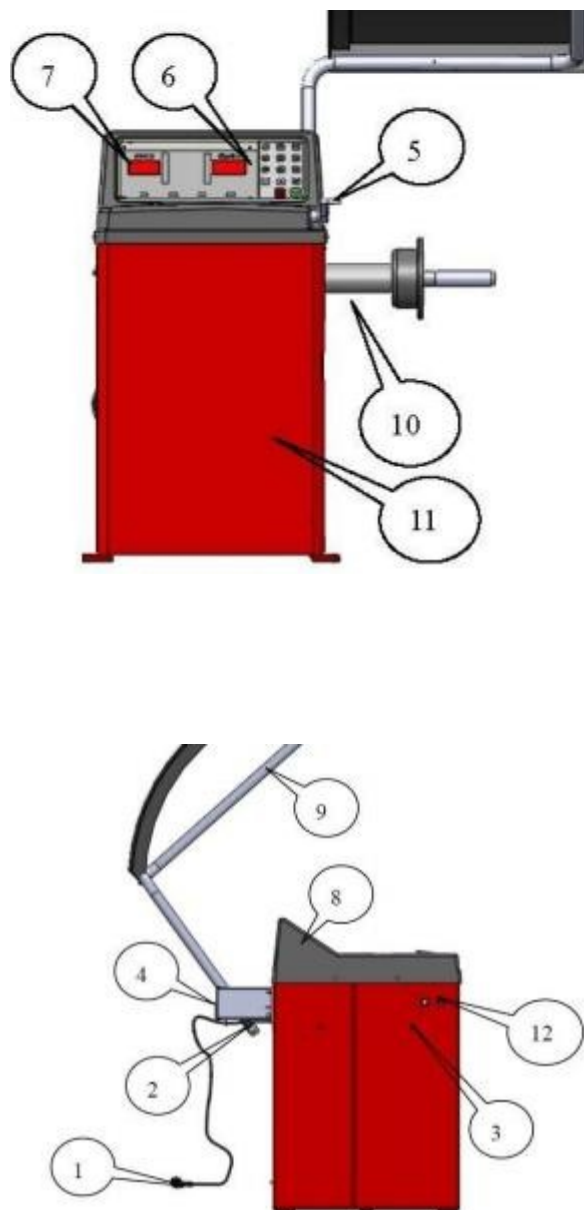

Fig. 8

- | | |
|------------------------|-------------------|
| 1. Power & Plug | 2. Return Spring |
| 3. Cone Storage Handle | 3. Main Switch |
| 5. Scale | 6. Control Panel |
| 7. Display | 8. Weight Tray |
| 9. Hood | 10. Balance Shaft |
| 11. Body | 12. Power Switch |

6.2 DISPLAY PANEL & CONTROL PANEL



Fig. 9



In the state of parameter input, it is the distance from wheel to balancer input key. You can change the Br set value of the window by press the up/down key.



Br value input key

You can change the Br set value of the window by press the up/down key.



In the state of parameter input, it is the diameter of the rim input key. You can change the D set value of the window by press the up/down key.



High accuracy balance key: When the display displays “00”, press this key the display will display the 5g of residual unbalance value.



Key for unbalance value recalculation/self-calibration

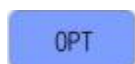

Unbalance optimized key

Realize the optimum of the unbalance value of rim and tire.



Key for balance mode selection



Key for dynamic balance or different static balance mode selection



STA mode



ALU1 mode



ALU2 mode



ALU3 mode



Emergency stop key



Start key



Inner unbalance value and parameters of the tyre display



Outer unbalance value and parameters of the tyre display

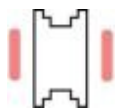



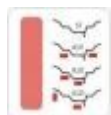















Unbalance position lamp



Balance mode indicating lamp

6.3 ACCESSORY

STANDARD ACCESSORY		
Accessory	Description	Quantity
	HOOD	1 SET
	CONE	1 SET
	PLIER	1 PIECE
	QUICK NUT	1 PIECE
	BOWL	1 PIECE
	BR SCALER	1 PIECE
	THREAD SHAFT	1 PIECE
	WEIGHT	1 PIECE
	BOWL CASE	1 PIECE

OPTIONAL ACCESSORY	
Accessory	Description
	LARGE CONE
	WEIGHT STICK SCALE
	DK-W- 1
	MJ-I
	4-POSITION ADAPTOR
	FLANGE DISK
	CENTERLESS RIM CALIP
	DK-W-2
	MJ-II

7. OPERATING INSTRUCTION

Caution:

The equipment can only be operated by qualified personnel with special training. Use appropriate tools, protective and safety equipment, wearing protective work clothes, such as blinkers and working tools.

Attention:

- The max. weight of the wheel cannot exceed 65kg.
- Remove any counterweight and other foreign body from the wheel before mounting it avoiding any danger. When remove the counterweight, the demounting/mounting pliers supplied with the machine should be used.
- Clean the contact surfaces between the shaft and the conical casing with alcohol or gasoline before mounting the wheel to avoid any influences on installation accuracy.
- Put the balancer on level ground as possible as you can.

7.1 MACHINE STARTUP

Switch on the main switch on the left side of the machine, the display will display "096" .

7.2 WHEEL MOUNTING

Installation methods of wheel: Positive positioning, negative positioning & flange disk when handling the middle and big sizes of tires. You can select the methods according to the different conditions.

7.2.1 SMALL CAR WHEEL POSITIVE POSITION

Positive positioning is the normal method. It is featured with simple and quick operation. It is mainly suitable to the common steel rim and aluminum alloy rim with small deformation.



Fig. 10

Main shaft → wheel (direction of the rim installation surface is inside) ⇄ cone → quick nut

7.2.2 When the deformation of the outside of the wheel, adopt this method to positioning to grantee the accurate positioning of the steel rim inner hole and main shaft. It is suitable to the steel rim, especially the thick ALU.



Fig. 11

Main shaft → tower spring ⇄ suitable cone → wheel bowl → quick nut

7.2.3 FLANGE DISK POSITIONING (OPTIONAL)

Suitable to the big tire assemble



Fig. 12

Main shaft → flange disk (fixed on the main shaft)

→ wheel → cone → quick nut

NOTE: The choice on the cone should be adapted to the rim center hole and pay attention to its direction. Or it will cause the inaccurate measurement.

7.3 BALANCE MODE SELECT

Select the balance mode according to the weight adding



position and the balance mode. Press the key to select the balance mode. When you switch on the machine the machine will automatic enter into the dynamic balance mode and no need to select.

Dynamic—clip the weight on both side of rim (dynamic balance test once start)

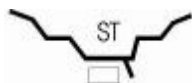

Static—use this mode when there can not add weight on both sides.



ALU1 - to balance the light aluminum alloy rim. Adopt clip the weight on the shoulders of the rim.

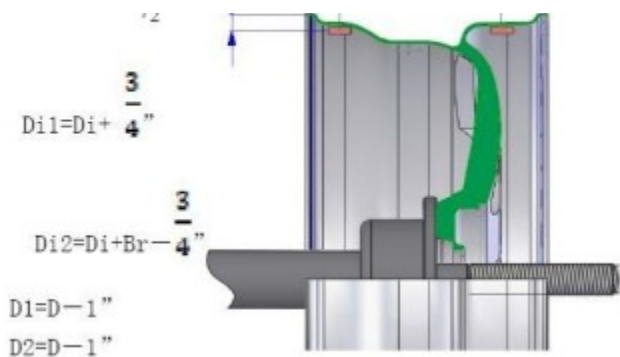

Fig. 14



ALU2 - for ALU rim, hidden weight inside.

ALU 2

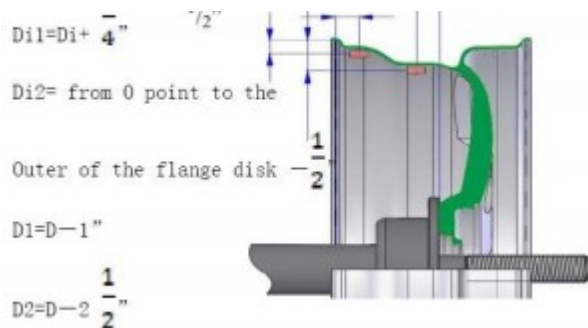

Fig. 15



ALU3 - clip the weight inside and the position to add weight outside is same to ALU2.

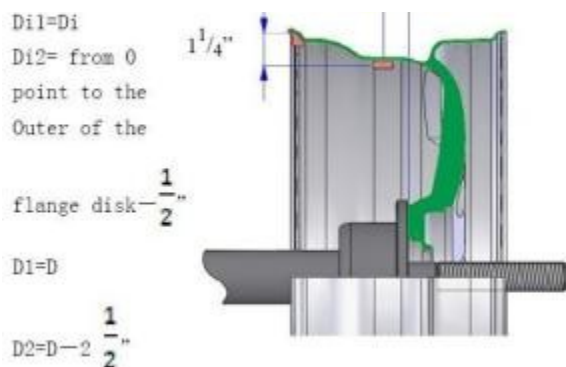

Fig. 16

7.4 VALUE INPUT

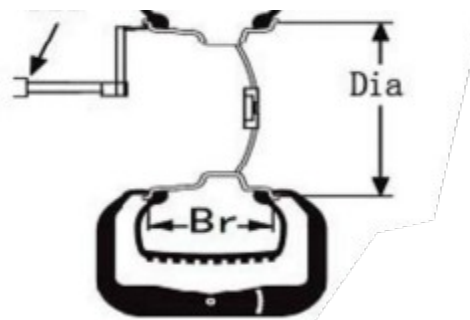





Fig. 13



7.4.1 Input Dis (Distance)

Pull the scale to the inner position to add the weight and



press the key  of  of  to input the DIS value into the display. At this moment, the display will display “DIS” : “XXX” . And the default system is mm.

7.4.2 Input Br (RIM Breadth) Value

Use the Br measurement caliper to measure the Br of the

 rim, press the key of  to input the Br value into the display. At this moment, the display will display “Br” : “XXX”

7.4.3 Input the Dia (Diameter) Tire Diameter Value



After confirming the rim diameter, press the key  of  of  to input the rim diameter into the display. At this moment, the display will display “D” : “XXX” .

7.5 SPINNING THE WHEEL

Press the start key  , the wheel balancer starts to run. A few seconds later, the machine automatically stops.

7.6 PLACING WEIGHTS

When the spin ends, the display will display the inner

 and outer  unbalance value of the rim. Use your hand to pull the wheel. When all the positioning lamps light inside and outside light, the weight adding position will be indicated.

Rotate the wheel, when the left side positioning lamp all light, at this moment, the highest position is the inner unbalance position and when the right side positioning lamp all light, at this moment, the highest position is the outer unbalance position.

Add the corresponding weight at the unbalance point and start test again until the balance of the tire.



- *When start the machine, use hand to pull the wheel to help it start rotation, especially to the relative bigger tire, to prolong the working life of the motor.*
- *Check if there are any mistakes on the dimension. Check if the balance methods meet the configuration of the rim and select the balancer most easily to balance.*
- *Check if the quick lock nut tight or not.*
- *When the balance ends, remove the tire. Pay attention to handle it with gentle and avoid knocking the main shaft.*
- *When clipping the weight. Use the hammer to clip the weight on the rim without too much force. Do not knock the main shaft hardly to avoid damaging the sensor. The position to add the Weight should be free from the grease and should be dry.*

7.7 RESIDUAL UNBALANCE VALUE DISPLAY

The minimum value of the standard weight is 5g so if the weight you use is less than 5 g, the wheel balancer will not display the value and only displays the state of “00” . When you need to display the residual unbalance value, you



should press  and the display will immediately display the inside or outside unbalance value of less than 5g. The maximum residual unbalance value is 4 g.

7.8 OPTIMIZED COINCIDENCE BALANCE OPERATION

This program is used for confirming the best coincidence position between the rim and tyre, complementing the imbalance of the rim with the imbalance of the tyre, so as to reduce the weight of the balance lead added, and reduce the noise caused by bad coincidence between the rim and tyre during driving. Generally speaking, user needn't perform this operation; only in special case—when the wheel satisfies the conditions of coincidence balance, can the experienced personnel perform this operation.

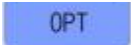

Before performing the coincidence balance operation, please install the wheel on the balancer to perform the dynamic balance operation. It is only necessary to measure the imbalance value, not necessary to stick the lead weight.

If the single side imbalance value of dynamic balance is more than 30g, carry out this operation.

Press  to enter into the operation. The display will show (OPT) (). Then press  key to perform the measurement. After the wheel stops rotating, the display shows (I) (180) which means the rim and the tyre should be rotated for 180 degrees comparatively. Mark the highest place of the wheel outside with chalk. Meanwhile mark the highest the place of the rim outside with chalk. Remove the wheel from the balancer, rotate the outer tyre relative to the rim, let chalk mark on the outer tyre rotated buy 180 degrees. After this, install the wheel on the balancer again. The balancer displays (45) (80). The data in the right display means the percentage of imbalance reduction. The data in the left display means the present imbalance value. Rotate the wheel slowly until all indicators are lit. Mark the highest place of the tyre with chalk. Rotate again the wheel until the inside imbalance indicator is lit. Mark the highest place of the rim with chalk. Remove the wheel from the balancer. Rotate the outer tyre relative to the rim until the two marks coincide. Install the wheel back to the wheel balancer again. After this operation, the 45g imbalance is reduced by 80%. The final imbalance value is 9g after optimized balance operation. Click a 10g balance weight is enough after optimization.

8. PROGRAM SETUP



8.1 MACHINE PARAMETER SETUP

Keep pressing  and  for five seconds until the position indicating lamps stop flashing. The system enters machine parameter setup program.

- **“DF” value setup**





Press a (↓) first , then a (↑), then (F) .After pressing a (↓) and a (↑), the display window shows nothing , after pressing (F) , the display window restores display , it shows (DF.) (125) .The left is <DF> value,press b(↑) or b(↓) to change the“DF” value.

- **“I” value setup**



Press  of  to the setup of “I” value. The display shows (I.-) (3). “-1” means positive value.



Press or  of  to change the “I” value.

- **“S” value setup**





Press  of  to the setup of “S” val The display shows (S) (330). Press  or  of  to change the “S” value.

- **Beeper setup**

Press  of  to up “on” and “off” of beeper.

Press  or  of  to set the “on” and “off” of the beeper.

● **Min. display value setup**

Press  of  to the setup of "EC" value. The display shows (EC) (05). Press  or  of  to select 5g, 10g or 15g.

Press  of  to exit the setup.

Note: During the setup, press  to stop the setup. The parameter will be back to the default value.

8.2 UNIT CONVERSION





8.2.1 The unit conversion of the Br of the rim from inch to mm:

Normally, the display of Br should be in inch. When you need the unit of the display to be mm, you can use the key

 and  or  of  to realize the unit conversion from inch to mm.

8.2.3 The unit conversion of the DIA of the rim from inch to mm:





Normally, the display of D should be in inch. When you need the unit of the display to be mm, you can use the key

 and  or  of  to realize the unit conversion from inch to mm.



After unit conversion, the unit of the display values of rim Br and D are mm, but when you switch off and then on the wheel balancer, the unit will be still inch.

8.2.4 The unit conversion from gram to ounce:

Normally, the unit of the unbalance value is gram (g). If you want to make the ounce (Oz) to be the unit, you can execute the g/Oz conversion. The unit of the displayed unbalance value is gram (g). The way to realize the unit

conversion from gram to ounce is to press  and 
or  of .

8.3 SELF-CALIBRATION

Install a medium size (13"~15") wheel. Input the rim parameters. Keep pressing the button  and press the button  at the same time. The display shows CAL-CAL. Loose the buttons when both of the unbalance indicators light and stop flashing. Press the start key to start the test. After running, the display will display ADD-100, rotate the tire until all of the unbalance position lamp light up. Clip a weight of 100g at the 12 clock position on the tire. Once again start the machine to realize the self- calibration of the machine.



Note: the 100g of weight to self-calibrate must be clipped at the 12clock position or it will cause the inaccuracy.

9. TROUBLE SHOOTING

9.1 ERROR INDICATION

Err 1: No rotating signal, motor does not rotate, wrong position sensor location, sensor damaged or bad connection, or computer board damaged.

Err 2: Low rotating speed or no wheel mounted on the machine (with tire).

Err 3: The imbalance value is too big. Change another wheel to test.

Err 4: Errors with power supply or position sensor.

Err 5: Not defined.

Err 6: Memory damaged or signal lost, calibrate again.

Err 7: Calibration error, pressure sensor cable cut or pressure sensor damaged, or bad connection of cable.

If you can not solve by the above mentioned method, pls contact with the professional persons.

Attention: *When change the computer board, the phase sensor or the press sensor, you must execute the self-calibration. When change the computer board, you should setup the parameter according to the parameter marked in the machine or on the original computer board. Repeat the self-calibration after the modification.*

9.2 FREQUENT ERRORS AND SOLUTIONS

Description	Cause	Solution
Start the machine but not display.	<ol style="list-style-type: none"> 1. Check the circuit of 220V is normal or not. 2. Power board fault 3. The cable between the power board and computer loose 4. Computer board fault 	<ol style="list-style-type: none"> 1. Check and connect the external power source. 2. Change the power board 3. Check the plug cable 4. Change the computer board
Display is normal but the start button and input push button not working.	<ol style="list-style-type: none"> 1. Contact switch not good 2. Machine breakdown 	<ol style="list-style-type: none"> 1. Open the housing of the machine and plug in and tight the contact switch plug. 2. Start the machine again
Display is normal but not braking after start.	<ol style="list-style-type: none"> 1. The cable between the power board and computer loose 2. Power board fault 3. Computer board fault 	<ol style="list-style-type: none"> 1. Plug in and tight the cable between the computer board and power board. 2. Change the power board 3. Change the computer board
Balance is not accurate & difficult to reach "00"	<ol style="list-style-type: none"> 1. Sensor lead connect or contact no good 2. Memory value lost 	<ol style="list-style-type: none"> 1. Connect again. 2. Correct the memory value according to the manual.
Each spin, the change of the value will not exceed 5g.	<ol style="list-style-type: none"> 1. There are foreign body on the rim or the assemble surface in the rim center deformation 2. Sensor damp or quick nut not tightly clamped 3. The external power voltage or the air pressure not enough. The flange dick not locked. 	<ol style="list-style-type: none"> 1. Change the wheel 2. Oven, recalibrate the sensor. 3. Fix the anchor bolt.
Each spin, the range of the change of value will be 20-90g.	<ol style="list-style-type: none"> 1. There are foreign bodies on the wheel or the unbalance of the wheel value too big. 2. Sensor damage 3. External power source voltage too low 	<ol style="list-style-type: none"> 1. Change the wheel 2. Check the sensor and wiring. 3. Check power source and assemble stabilizer.
Balance is not accurate & difficult to reach "00"	<ol style="list-style-type: none"> 1. Sensor damp or damage 2. Program chore 	<ol style="list-style-type: none"> 1. Calibrate again, oven and then self-calibration or change. 2. Self-calibration again
When second mount & demount, the error will exceed 10g.	<ol style="list-style-type: none"> 1. Wheel internal hole irregular 2. Flange disk assemble not properly 	<ol style="list-style-type: none"> 1. Change the wheel 2. Check the assemble surface and try again.

10. MAINTENANCE



WARNING

The manufacturer will not bear any responsibility in the event of claims resulting from the use of non-original spare parts or accessories.



WARNING

Unplug the machine from the socket and make sure that all moving parts have been locked before performing any adjustment or maintenance operation.



WARNING

Do not remove or modify any part of the machine (except for service interventions).



CAUTION

Keep the work area clean.

Never use compressed air and/or jets of water to remove dirt or residues from the machine. Take all possible measures to prevent dust from building up or rising during cleaning operations. Keep the wheel balancer shaft, the securing ring nut, the centering cones and nange clean. These components can be cleaned using a brush previously dipped in environmentally friendly solvents. Handle cones and nanges carefully so as to avoid accidental dropping and subsequent damage that would affect centering accuracy. After use, store cones and nanges in a place where they are suitably protected from dust and dirt. If necessary, use ethyl alcohol to clean the display panel. Perform the calibration procedure at least once every six months.

LUBRICATION

The only rotating parts of the wheel balancer are the motor and balance shaft. These parts must be periodically lubricated by the operators. If the machine is used very frequently, more than 2hours per day, we should annually

check the bearing. And we will check once a year if the machine is used less than 2hours a day. When test, do not open up the bearing so you need insert a screwdriver to test the noise. Due to the function of the bearing is to clamp and support and not suitable to change or remove the grease. In addition, the speed of it is not too fast compared to the machine so no need to change the grease. If you note the run of the bearing abnormal or there is noise, change the bearing. If the customer confirms the bearing is not changed, you only need change the grease. Disassemble the bearing and open up the sealing ring and fill the XHP103 grease. These operation should be guided by the profession personnel and calibrate the machine after changing the grease. If the change of the grease not correctly, it will influence the accuracy of the machine. On this condition, you need to reinstall the sealing ring and assemble the machine and adjust again.

Technical safety card for using grease in the wheel balancer.

Mobilgrease XHP

NLGI degree

Type of thickener

Colour, appearance

Penetration on the processed item 25°, ASTM D 217, mm/ 10

Dropping point, °C, ASTM D 2265

Viscosity oil base, ASTM D 445, cSt @ 40°C

Change of penetration consistency, ASMT D 1831 (established upon the rolling of the greases), mm/ 10

4 spheres test, impression diam., ASTM D 2266, mm

4 spheres test, welding load, ASTM D 2509, kg

Test Timken OK load, ASTM D 2509, lb

Stability of oxidisation bomb method, ASTM D 942, pressure drop at 100 hours, kPa Corrosion prevention, ASTM D 1743

Emcor rust, IP 220, wash away with acid water

Rust protection, IP 220-mod, wash away with distilled water

Corrosion on copper, ASTM D 4048 1A

Wash away with water, ASMT D 1264, loss (weight%), @ 79°C 5

SCRAPPING

If the machine is to be scrapped, separate all electrical, electronic, plastic and ferrous components and dispose of them separately, as provided for by local regulations in force.

ENVIRONMENT INFORMATION

If the machines have the crossed-out bin symbol on their



data plate, the following disposal procedure must be applied to. This product may contain substances that can be hazardous to the environment and to human health if it is not disposed of properly.

Electrical and electronic equipment must never be disposed of in the usual municipal waste but must be separately collected for their proper treatment.



The crossed-out bin symbol, placed on the product and on this page, reminds the user that the product must be disposed of properly at the end of its life.

Thus, the hazardous consequences that non-specific treatments of the substances contained in these products, or improper use of parts of them, may have on the environment or on human health are prevented. Furthermore, this helps to recover, recycle and reuse many of the materials contained in these products.

Electrical and electronic manufacturers and distributors set up proper collection and treatment systems for these products for this purpose.

Contact your local distributor to obtain information on the collection procedures at the end of the life of your product.

When purchasing this product, your distributor will also inform you of the possibility to return another end-of-life piece of equipment free of charge as long as it is of equivalent type and had the same functions as the purchased product.

Any disposal of the product performed in a different way from that described above will be liable to the penalties provided for by the national regulations in force in the country where the product is disposed of.

Further measures for environmental protection are recommended: recycling of the internal and external packaging of the product and proper disposal of used batteries (only if contained in the product).

Your help is crucial to reduce the amount of natural resources used for manufacturing electrical and electronic equipment, minimize the use of landfills for product disposal and improve the quality of life, preventing potentially hazardous substances from being released in the environment.

FIREFIGHTING MEANS TO BE USED

Consult the following table to choose the most suitable fire extinguisher.

Dry materials

Water YES

Foam YES

Powder YES*

CO2 YES*

YES* Use only if more appropriate extinguishers are not at hand or when the fire is small.

Flammable liquids

Water NO

Foam YES

Powder YES

O2 YES

Electrical equipment

Water NO

Foam NO

Powder YES

CO2 YES



Warning

This table contains general instructions to be used as guidelines for users. All the applications of each type of extinguisher must be obtained from the relevant manufacturer.

APPENDIX

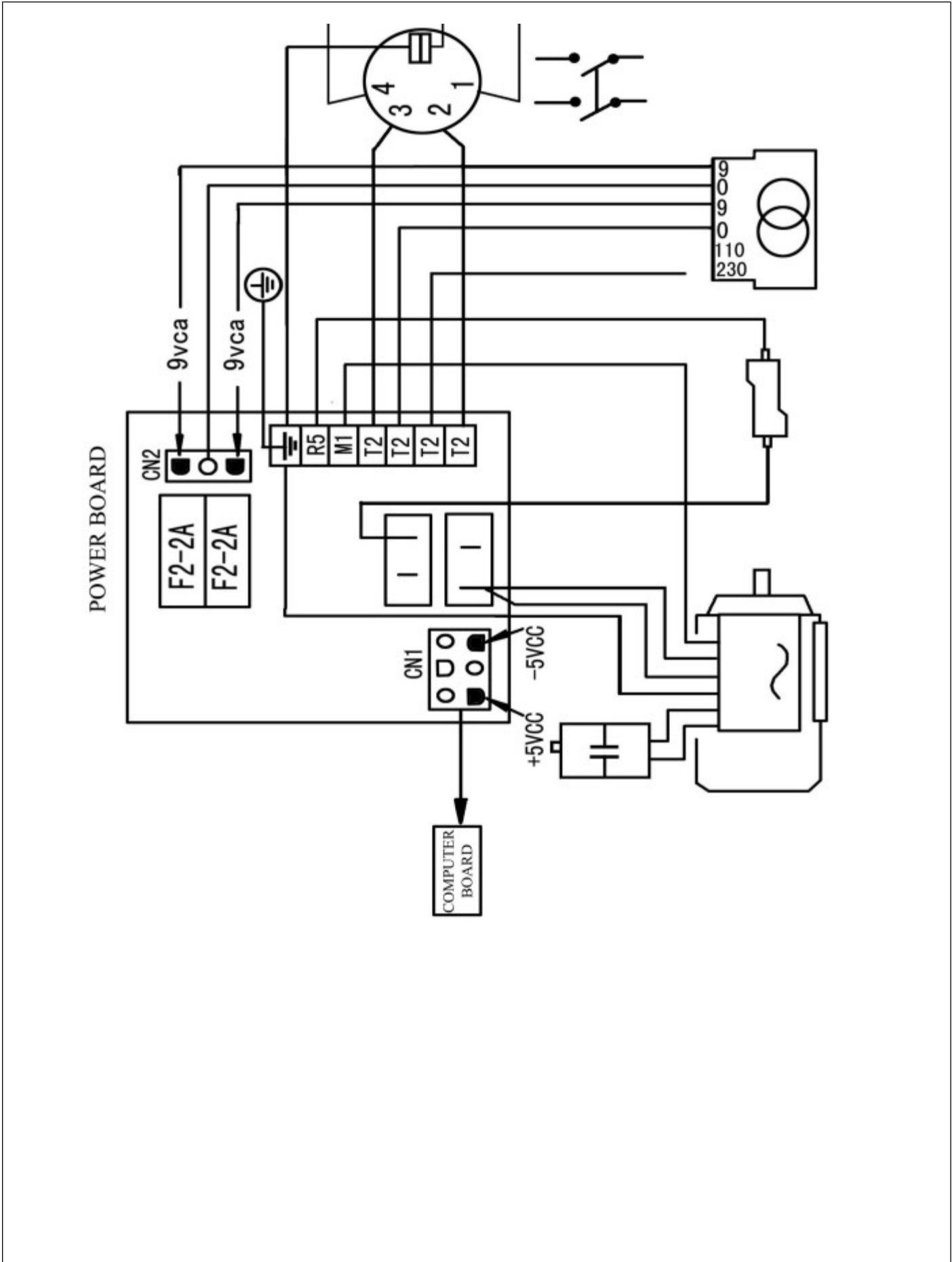

WARRANTY

The wheel balancer is warranted for one year from the date of goods delivery to the original purchaser, to be free of defects in material and workmanship.

The manufacturer shall repair or replace at their option for this period those parts returned to the factory freight prepaid which prove after inspection to be defective.

This warranty only applies to the original purchaser of the equipment. This warranty does not extend to defects caused by ordinary wear, abuse, misuse, shipping damage, or damage as the result of improper maintenance.

This warranty is exclusive and in lieu of all other warranties expressed or implied.

In no event shall the manufacturer be liable for special, consequential or incidental damages for the breach or delay in performance of the warranty.

The manufacturer reserves the right to make design changes or add improvements to its product line without incurring any obligation to make such changes on product sold previously.

DECLARATION OF CONFORMITY

According to ISO/IEC Guide 22 and EN 45014

Manufacturer: Foreintrade S.A

Manufacturer's address: Janówek, ul. Modrzewiowa 54 05-555 Tarczyn

WE DECLARE THAT THE PRODUCT IS COMPLIANT WITH EUROPEAN STANDARDS

Product name: Wheel balancer(marked with the Kraft&Dele trademark)

Model (trade designations): KD5841

Declaration:

The product to which this declaration refers meets the requirements of EC Directives:

1. 2006/42/EC Machinery Directive

According to standards:

EN ISO 12100:2010; EN 60204-1:2018

Person responsible for maintaining technical documentation: Ma Dong Hui, Janówek, ul. Modrzewiowa 54 05-555 Tarczyn

Ma Dong Hui, Tarczyn, 01.01.2025

Foreintrade S.A
Janówek, ul. Modrzewiowa 54
05-555 Tarczyn
NIP: 521-36-70-752; Regon: 147383292

